

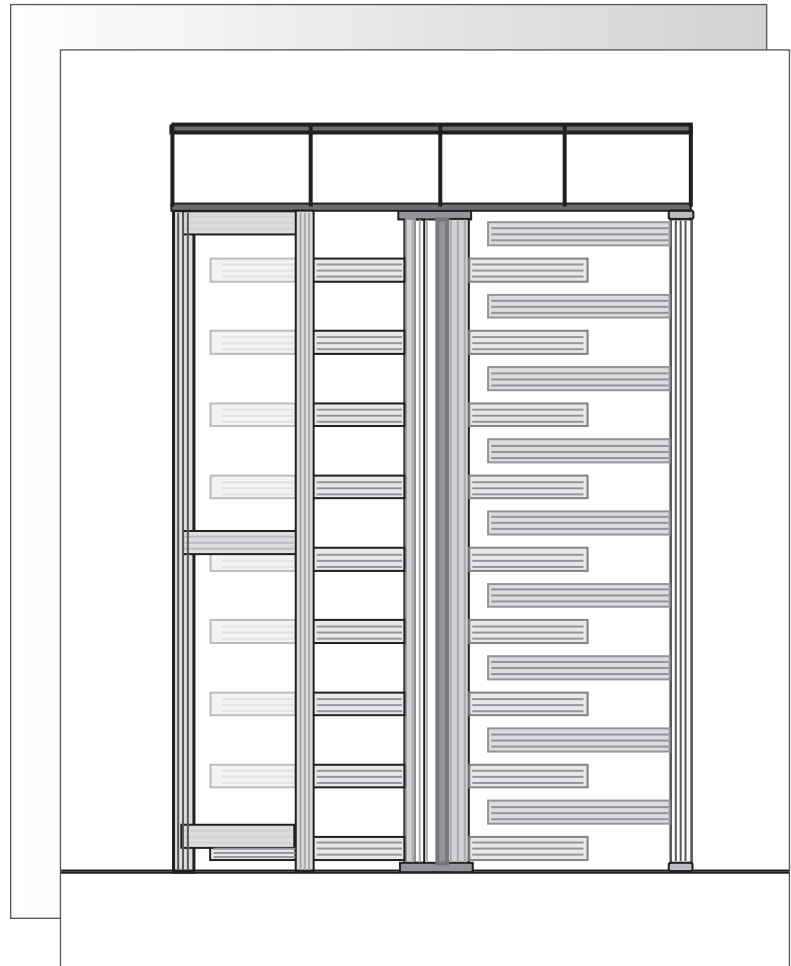

**FULL HEIGHT
GALVANIZED STEEL TURNSTILE
SINGLE UNIT**



AT-FST SERIES

**INSTALLATION AND OPERATING INSTRUCTIONS
WWW.AIGISMECH.COM**

SAFETY PRECAUTIONS

	CAUTION RISK OF ELECTRIC SHOCK	
CAUTION: TO REDUCE RISK OF SHOCK, DO NOT SERVICE WITH THE POWER ON. REFER SERVICING TO QUALIFIED SERVICE PERSONNEL.		



The lightning flash with an arrowhead symbol within an equilateral triangle is intended to alert the user to the presence of non-insulated "dangerous voltage" within the product's enclosure that may be of significant magnitude to constitute a risk of shock to persons



The exclamation point within an equilateral triangle is intended to alert the user to presence of important operating and maintenance (servicing) instructions in the literature accompanying the product.

WARNING: TO PREVENT FIRE OR SHOCK HAZARD, DO NOT EXPOSE THE INSIDE OF THE HEADER TO RAIN OR EXCESSIVE MOISTURE



Attention: Qualified personnel only in accordance with National Electrical Code or applicable local codes should perform installation and servicing

WARNING: 120 VOLT POWER MUST BE OF AMPLE SUPPLY FOR OPERATING THIS EQUIPMENT SAFELY AND IT MUST BE PROPERLY GROUNDED.
--

CONTENTS

- 1. SITE PREPARATION
- 2. EXPLODED VIEW DRAWING
- 3. UNPACKING
- 4. INSTALLATION
- 5. FUNCTIONAL TEST
- 6. MAINTENANCE
- 7. SERVICE

1 SITE PREPARATION

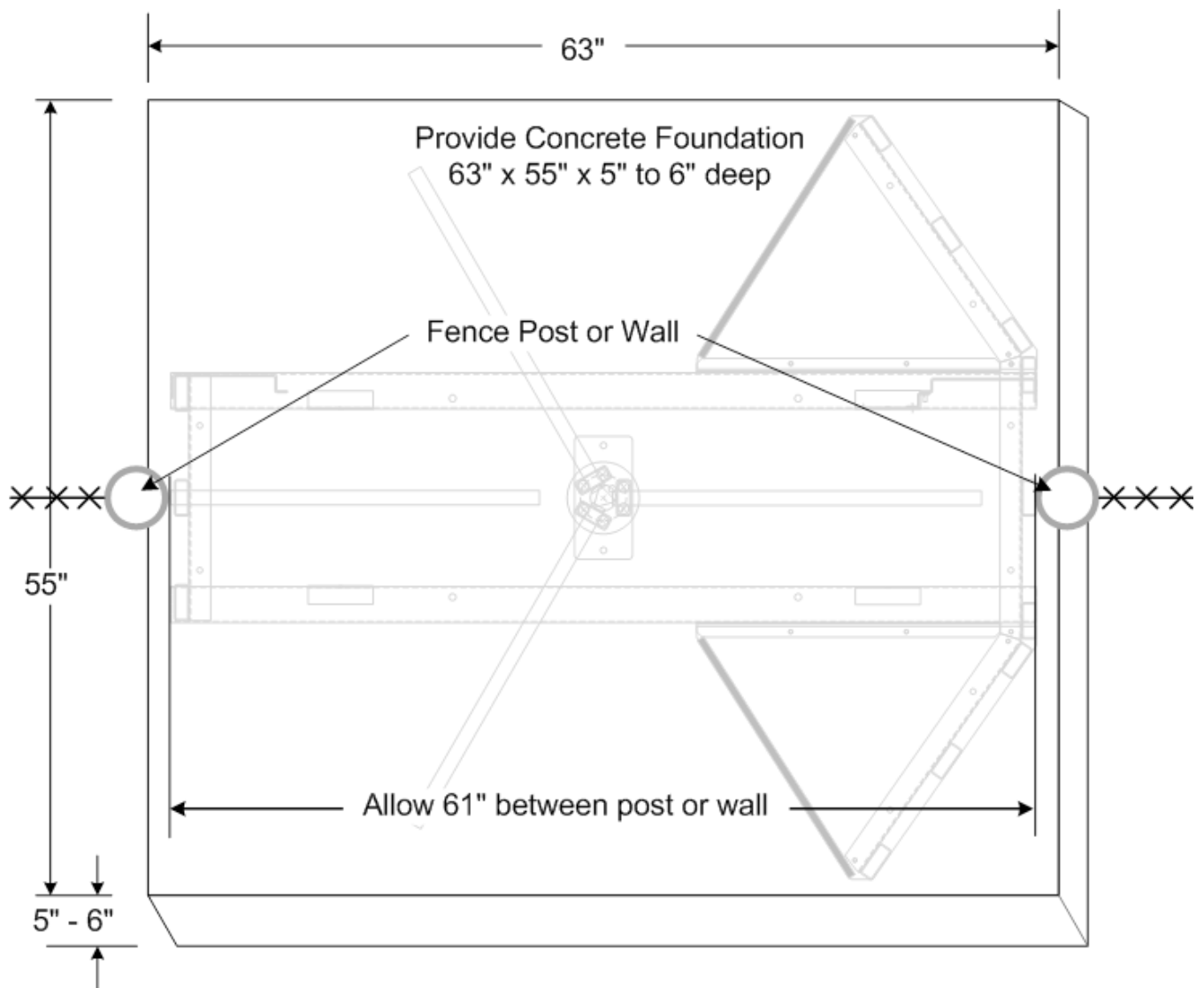

Figure ST-1 Site Preparation

2 EXPLODED VIEW DRAWING (EVD)

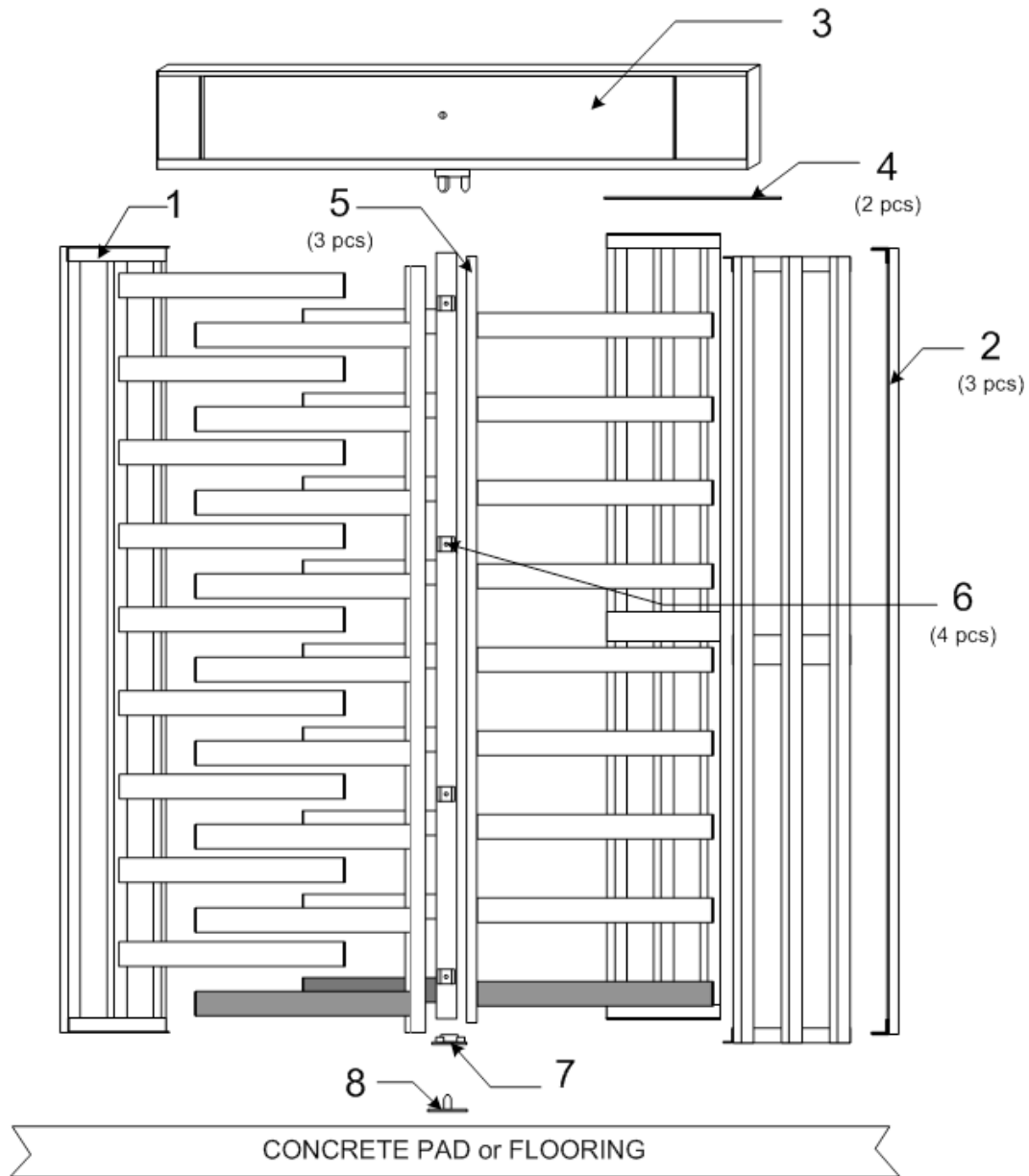

Figure ST-2 Main Components

- | | |
|-----------------------------------|----------------------------------|
| 1 - BARRIER ASSEMBLY | 5 - SPINDLE ARM ASSEMBLIES |
| 2 - PASSAGE PANELS | 6 - SPINDLE CONNECTOR NUTS |
| 3 - HEADER / MECHANISM ASSEMBLIES | 7 - LOWER BEARING HOUSING |
| 4 - CEILING PLATES | 8 - SPINDLE PIVOT MOUNTING PLATE |

3 UNPACKING

The Turnstile is packaged to allow the installer to work out of the crate as the installation progresses.

Check to insure that the following parts are included for the applicable turnstile ordered:

NOTE: The following list is shown in the order that they will be required for installation.

1 BOX MOUNTING AND INSTALLATION HARDWARE		
Quantity	Description	Part # on Drawing
4	Spindle Connector Nut	6
1	Spindle Pivot Mounting Plate	8
1	Lower Bearing & Housing	7
4	Cabinet Keys	N/A
10	3/8" X 3-3/4" Anchor Bolt w/ Washer and Nut	N/A
4	5/16-18 X 3/4" Header Mounting Bolt w/ Nut and Washers	N/A
12	5/16-18 X 1 3/4" Spindle Arm Assembly Bolt	N/A
10	1/4 -20 X 1/2" Ceiling Plate Screw	N/A
10	1/4 -20 Nylock Nut	N/A

INDIVIDUALLY WRAPPED COMPONENTS		
Quantity	Description	Part # on Drawing
1	Barrier Assembly	1
3	Passage Panel	2
1	Header & Mechanism	3
2	Passageway Ceiling Panel	4
3	Spindle Arm Assembly	5

4 INSTALLATION

NOTE: FOLLOW THE BELOW INSTRUCTIONS CLOSELY. THE ORDER OF INSTALLATION AND ASSEMBLY IS CRITICAL TO A SUCCESSFUL INSTALLATION.

- REMOVE AND POSITION THE BARRIER ASSEMBLY (PART #1 ON EVD)

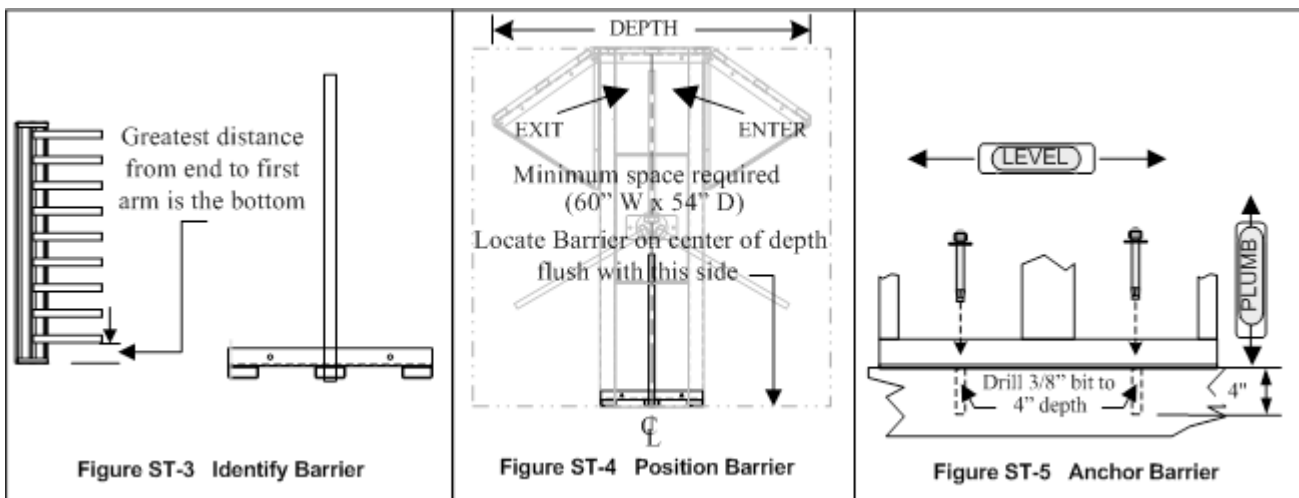

- Position Barrier in exact place to be installed.
- LEVEL AND PLUMB all sides.
- Drill and set anchor bolts.

- **REMOVE ONE OF THE PASSAGE PANELS (PART # 2 on EVD)**

NOTE: All Passage Panels are identical.



CAUTION: Exact positioning of the Center Passage Panel in relationship to the already installed Barrier is critical to a successful installation.

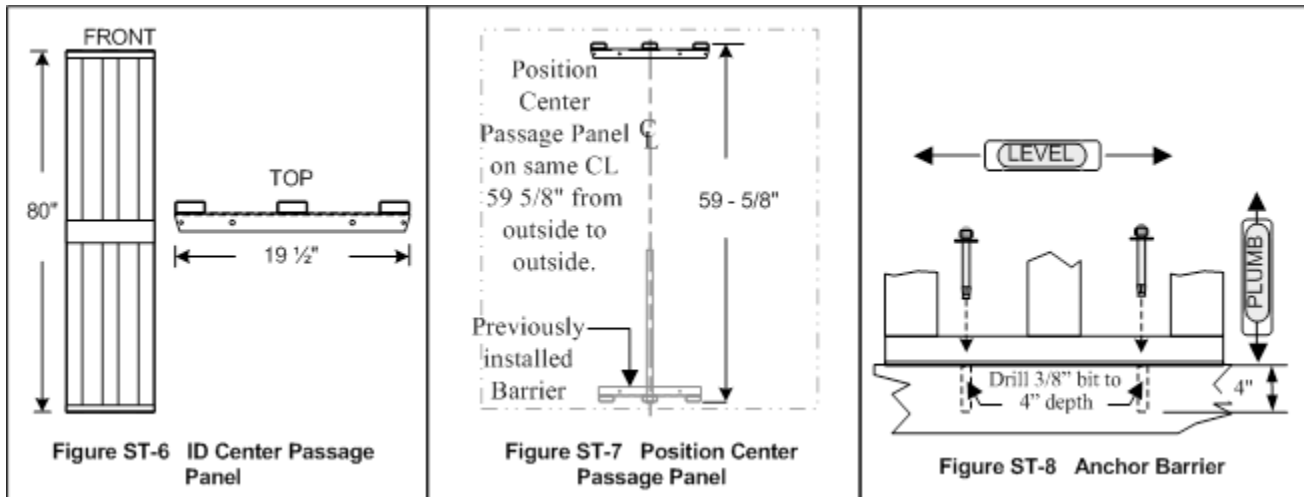

- Position and anchor Center Passage Panel as shown above. The angle parts of the assembly face inward toward the Barrier.
- **REMOVE AND INSTALL THE HEADER / MECHANISM ASSEMBLY (PART # 7 on EVD)**

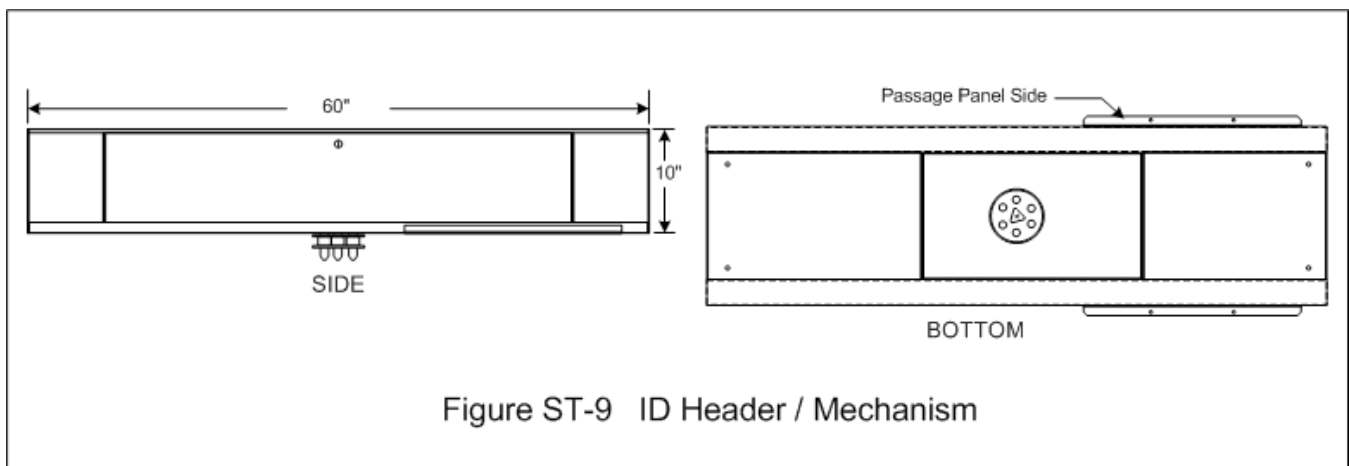

- **INSTALL HEADER / MECHANISM**

- Lift the Header and Mechanism and set it on top of the Center Passage Panel and the Barrier as shown in figure ST-10 below. Note that the side with the Ceiling Plate Support Rails goes to the Center Passage Panel side.
- Open the doors of the Header and secure the Header and Mechanism to the Passage Panel and Barrier using the 5/16x3/4 Bolts provided. Use washers and nuts as shown in Figure ST-10 below.

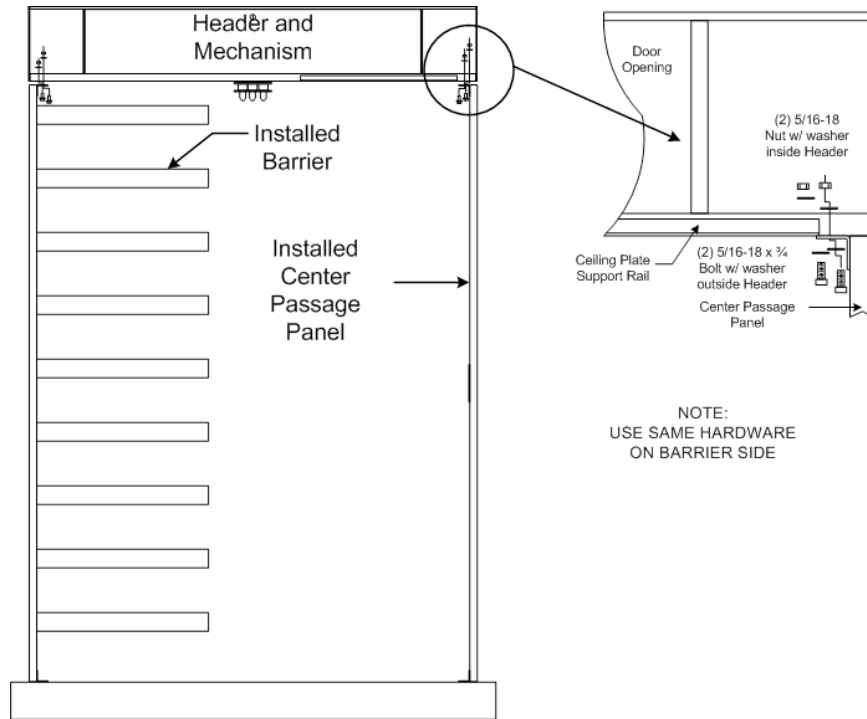
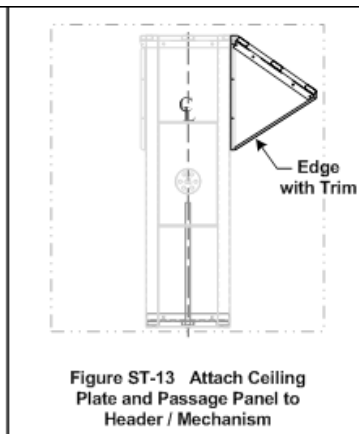
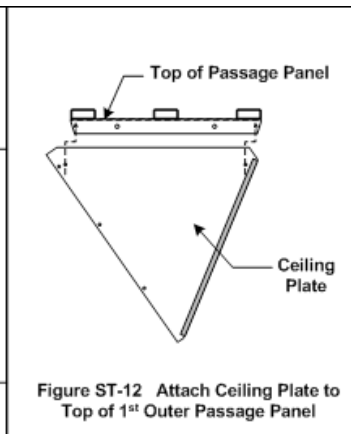
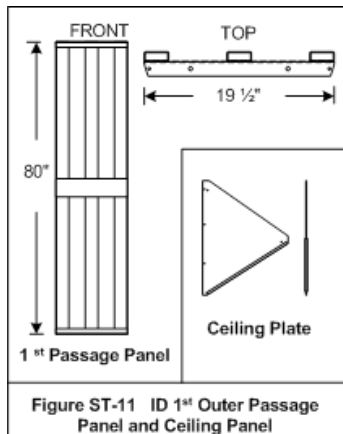
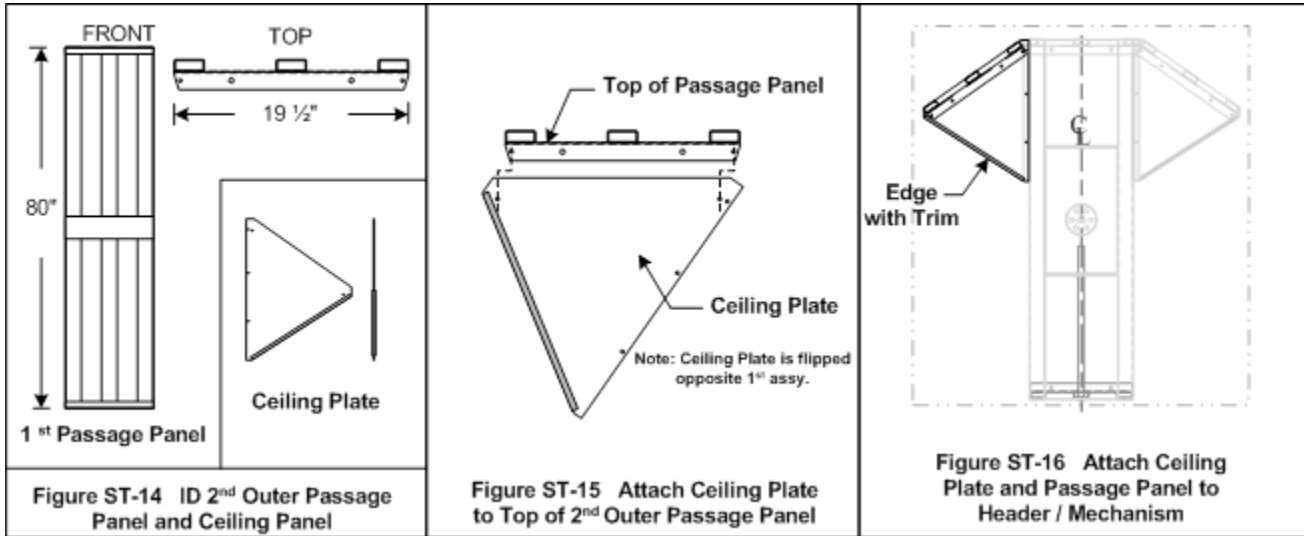

Figure ST-10 Install Header / Mechanism

- **INSTALL AND ANCHOR OUTER PASSAGE PANELS AND CEILING PLATES (PART # 2 & 4 ON EVD)**



- Using the 1/4-20 x 1/2" Button Head Screws and 1/4-20 Nylock Nuts, loosely attach a Ceiling Plate to the top of the Passage Panel as shown in Figure ST-12 above. Place the Nylock nuts on the Ceiling Plate side and use the 1/4" washers on bottom side.
- Attach the Ceiling Plate / Passage Panel assembly to the Header using the same 1/4-20 x 1/2" Button Head Screws and Nylock nuts.
- Note the orientation of the Ceiling Plate edge with trim as shown in figure ST-13 above.



- Attach the 2nd Ceiling Plate / Passage Panel assembly the same way to the other side of the Header.
- Anchor both End Passage Panels as shown in Figure ST-17 below

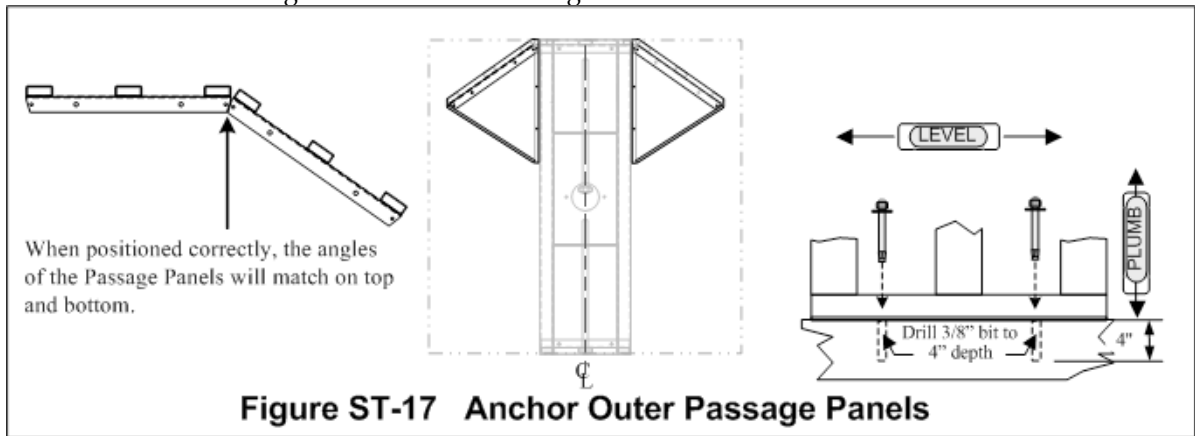

- **INSTALL SPINDLE ARM ASSEMBLIES**
- Lift the Operating Mechanism to the install position.

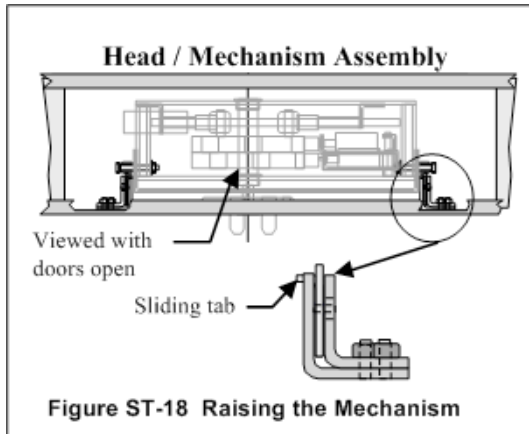

Figure ST-18 Raising the Mechanism

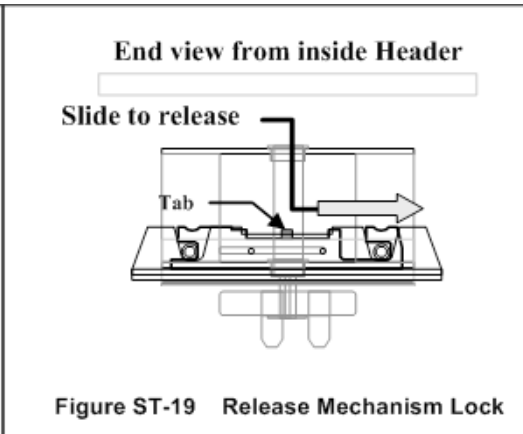

Figure ST-19 Release Mechanism Lock

- From inside the Header, slide the tab of the mechanism lock on both sides to release the mechanism.

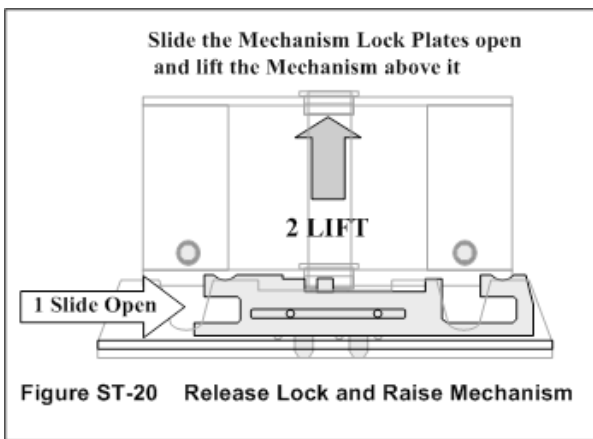

Figure ST-20 Release Lock and Raise Mechanism

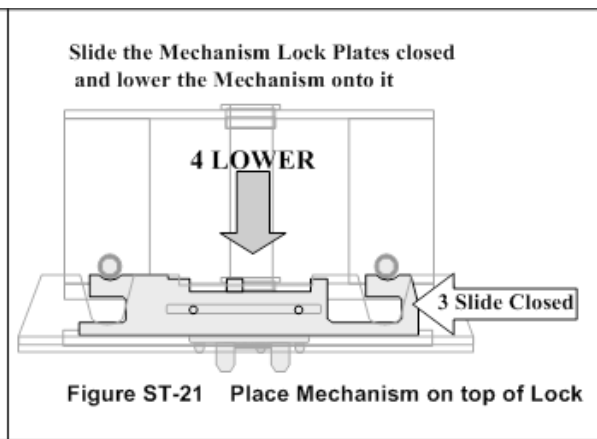

Figure ST-21 Place Mechanism on top of Lock

- From beneath lift the mechanism straight upward (two persons) until the slide bar tabs are accessible.
- Slide the tabs back to closed position and gently set the mechanism on it as shown in **Figure ST-21**.
- ASSEMBLE THE SPINDLE ARM SECTIONS**

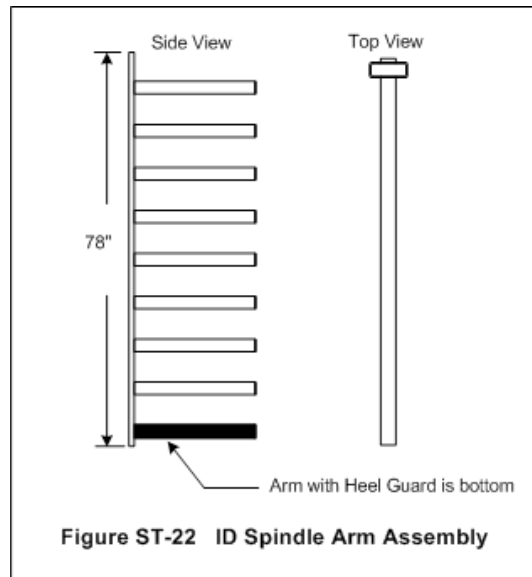

Figure ST-22 ID Spindle Arm Assembly

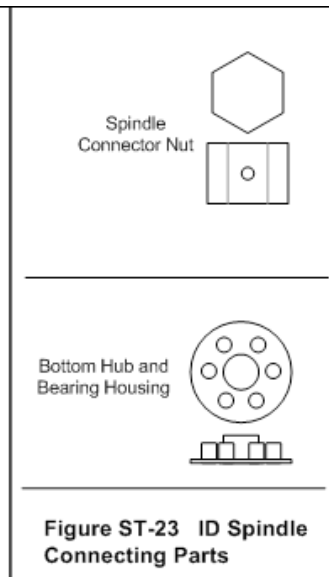

Figure ST-23 ID Spindle Connecting Parts

- Remove the 3 Spindle Arm Assemblies along with the 4 Spindle Connector Nuts, 3 Spindle Upper Support Brackets and 1 Bottom Hub. See Figure ST-23 above for identification.
- Assemble the 3 Spindle Arm Assemblies together as shown in Figure ST-24 below. Do the assembly close to the installation but not underneath it.

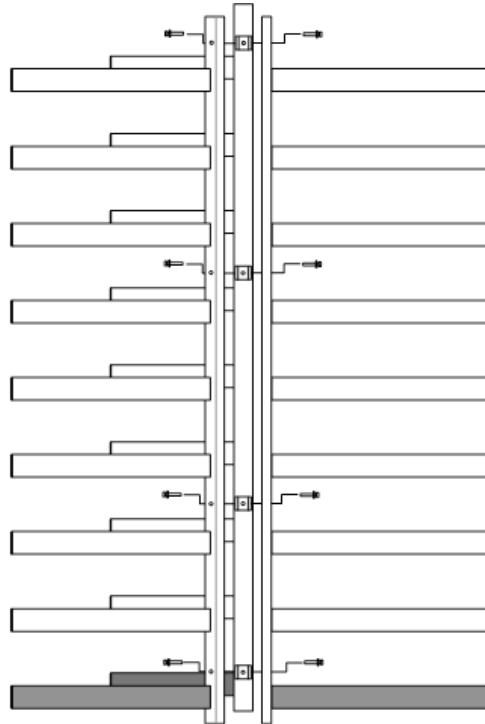

Figure ST-24 Assemble Spindle Arm Sections

- Starting at the bottom near the Heel Protectors, loosely bolt the spindle connector Nuts to the Spindle Assemblies using the 5/16 x 1 3/4 bolts provided. A 5/16 washer goes against the head of the bolt.
- Repeat for the next three Spindle Connector Nuts.
- **ATTACH THE LOWER HUB TO THE ASSEMBLED SPINDLE ARMS**

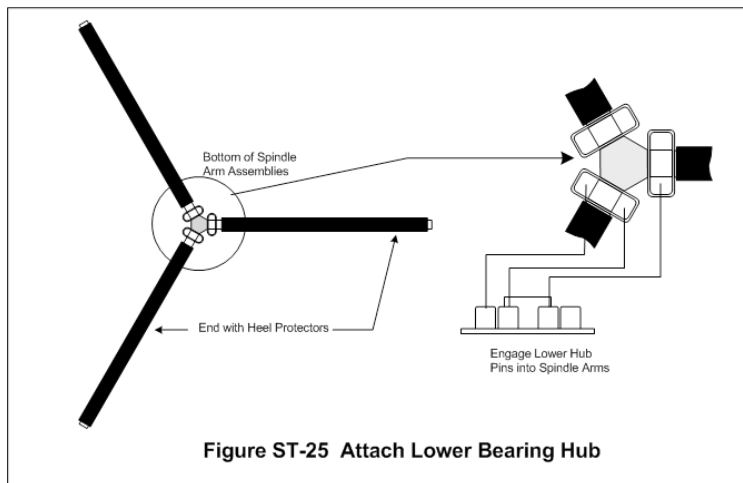
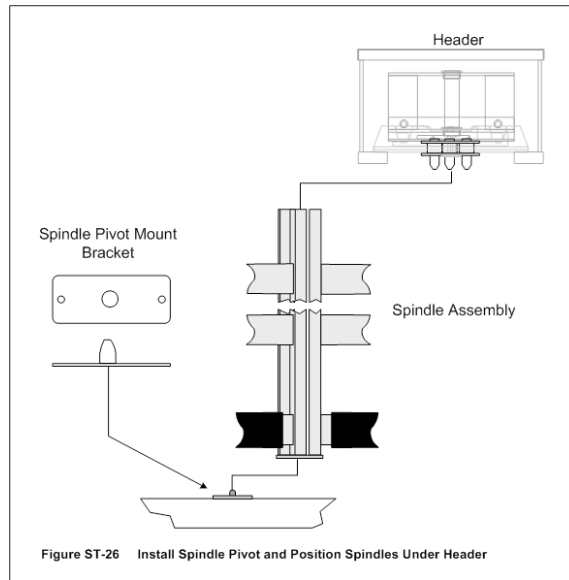

Figure ST-25 Attach Lower Bearing Hub

- Attach the Lower Hub to the Spindles by engaging the pins of the hub into the Spindle Arm Sections. Two pins will engage each Spindle Arm Section.
 - Note that you may need to tap on the Hub to get the pins engaged.
- **ATTACH THE SPINDLE PIVOT MOUNT AND POSITION THE ASSEMBLY**



- Insert the Spindle Pivot Mount into the Lower Bearing and stand the assembly up to rest on the Pivot Mount.
- Slide the entire assembly under the turnstile header and mechanism hub as shown in figure ST-26 above.

INSTALL THE SPINDLE ARM ASSEMBLIES

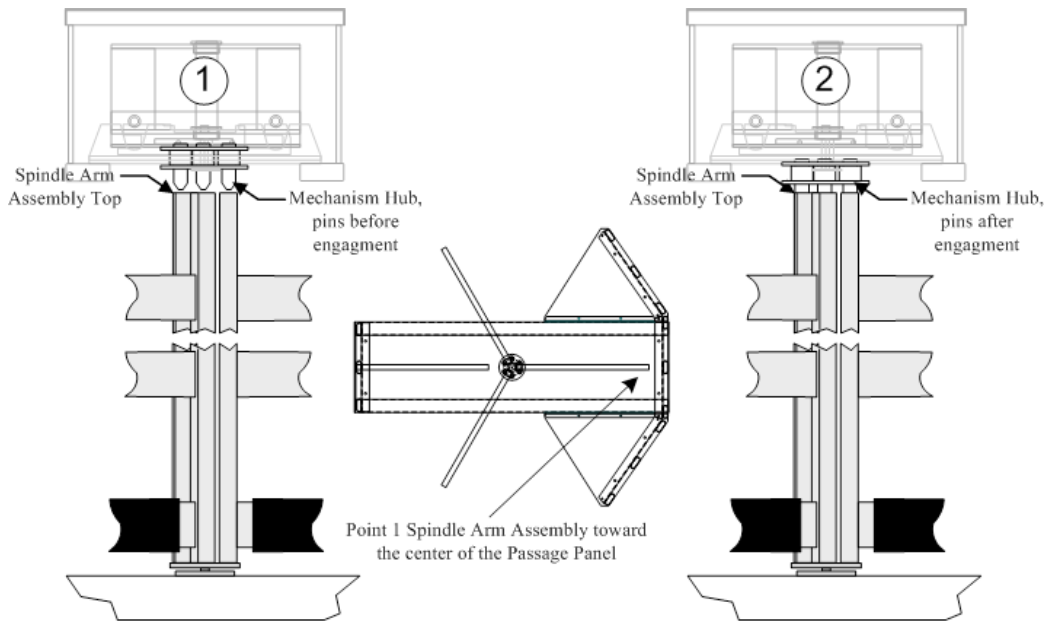

Figure ST-27 Position Spindle Arms and Pivot Under Header Hub

Figure ST-28 Engage Hub Pins into top of Spindle Assembly

- Slide the Upper Hub up the shaft and position the Spindle Assemble under the Hub. See figure ST-27 above.
- Turn the Spindle Assembly until one set of the arms are pointing to the middle of the Center Passage Panel.
- Slide the Upper Hub down the shaft and engage the hub pins into the Spindle Arm Assemblies. See figure ST-28 above.
- **LOWER AND LOCK DOWN THE MECHANISM.**



CAUTION: When lifting the mechanism to slide the tab for receiving, do not lift too high because the hub will disengage the center column.

- Lower the mechanism in the reverse manor of when it was lifted.

Lift mechanism up just enough to operate slide tab

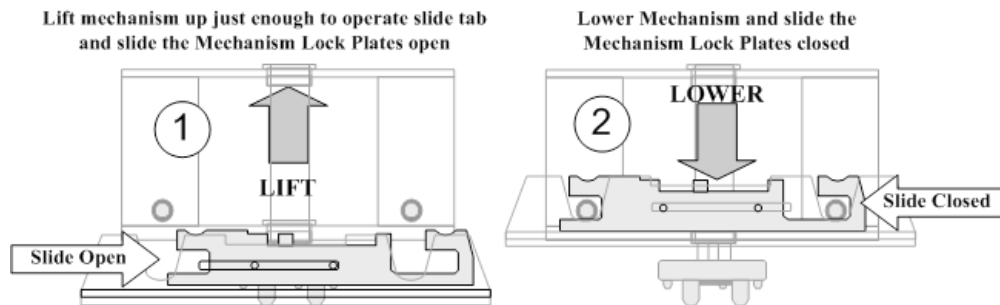

Figure ST-29 Lower Mechanism and Lock

- Insure that all the pins in the Hub are fully engaged into the Center Column and Spindle Arm Assemblies.
- Slide the mechanism lock plates to the locked position.
- **SQUARE, PLUMB and ANCHOR the Spindle Arm Assembly and Pivot Mount**
- Tighten all bolts before square and plumb step.
- SQUARE and PLUMB the Spindle Arm Sections (Figure ST-30 below).
- Anchor the Spindle Pivot Mount Plate (Figure ST-30 below).

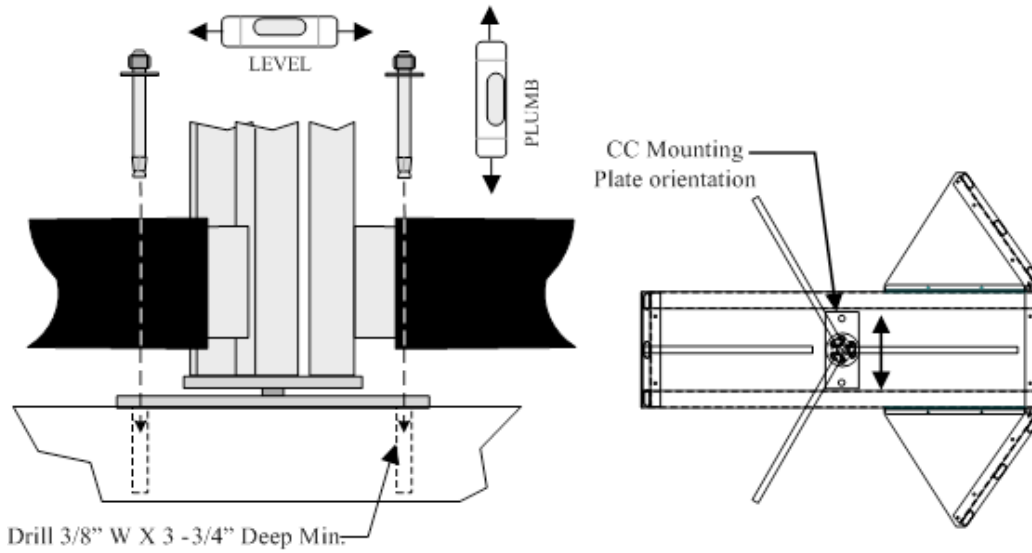

Figure ST-30 Anchor the Spindle Pivot Mount

- **SECURE THE TOP OF THE TURNSTILE TO FENCE POSTS OR WALLS**

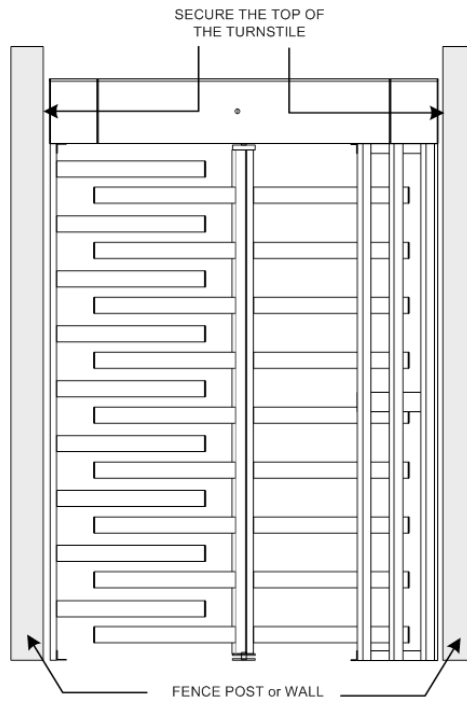

Figure ST-31 Secure the top of Turnstile

- Secure to top of the turnstile to prevent top sway.

▪ **WIRING FOR THE STATUS INDICATOR LIGHTS**



CAUTION: Standard anti-static procedures should be observed when handling the Status Light Boards. It is recommended you ground yourself to the turnstile frame before handling the board. Remain in contact with the turnstile while handling the board.

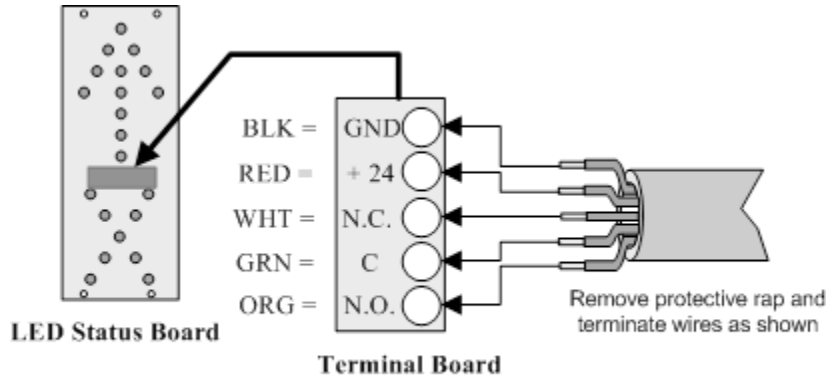
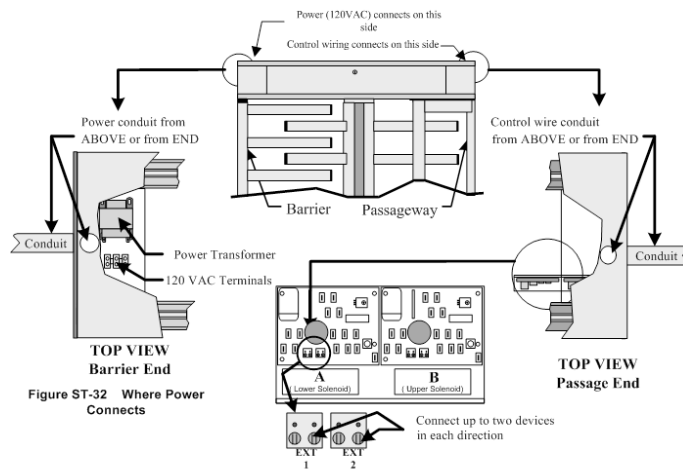

Figure 23 Status Light Wiring

- Remove the Status Light Cover using the #10-24 screws.
- Remove the Status Light assembly from the mullion using the #4-40 screws.
- Connect the wires to the terminal block on the Status Light Board as shown in Figure 23 above.

ELECTRICAL CONNECTION:

- 120 VAC power connection
 - Power for the turnstile must come into the header cabinet. Depending on the requirements of the site, it can either come in from the top or from one end of the cabinet.
 - Where there are multiple turnstiles in a row it may be necessary to pass through from turnstile to turnstile with the power and control wires.





CAUTION: When drilling into cabinet do not allow metal chips to fall on or near electrical components. Collect all chips and insure area is clean before applying power.

- Use watertight connections where entering the cabinet with conduit.
- Connect power to terminal block as labeled.
- **CAUTION:** Standard anti-static procedures should be observed when handling the Turnstile Control Boards. It is recommended you ground yourself to the turnstile frame before handling the board. Remain in contact with the turnstile while handling the board.
- Connect card reader, pushbutton or other control contacts to either EXT1 or EXT2.
- Access control devices (Card Readers, Pushbuttons, etc.) must provide a momentary dry contact closure to activate the turnstile for one pass.

5 FUNCTIONAL TEST

- 1 With all electrical connections made, turn power on and perform a functional test of the turnstile.
- 2 When power is applied the turnstile center spindle arms should be locked. Try to rotate the arms in either direction. They should not rotate!

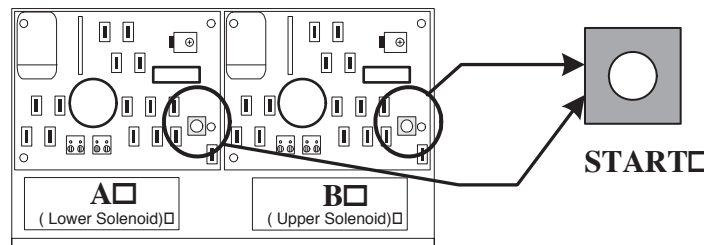

Figure 44 Start Button Location

3 TEST ROTATION

- a. On the control board of the direction of rotation to be tested first, push the START button.
- b. The solenoid that controls the direction being tested will release the locking pawl from the ratchet and allow the spindle arms to rotate.
- c. Push the turnstile arm sections in that direction, they should rotate for one cycle (120 degrees) and then re-lock automatically.
- d. Repeat a minimum of three times in each direction of rotation being tested.

4 TEST RELOCK TIMER

- a. Push the START button and the solenoid will activate the locking pawl. Wait ten seconds and the solenoid will de-activate the locking pawl.
- b. Push the START button and the solenoid will activate the locking pawl. Rotate the spindle arms approximately 10 degrees and hold in that position for more than 10 seconds, the solenoid will continue to activate the locking pawl.

5 TEST THE CENTERING MECHANISM

- a. Push the START button and rotate the spindle arms to just past $\frac{1}{2}$ cycle. Stop the arms there and release them. They should rotate on their own and finish the cycle to the home position.

6 TEST THE ACCESS CONTROL DEVICE(S)

- a. Repeat the steps in number four above except use the access control device (Card Reader, Pushbutton, etc.) instead of the START button on the controller.

7 VERIFY THE STATUS LIGHTS ARE FUNCTIONING

- a. Verify that the red X status light is on before presenting the card.
- b. Present the card, the red X status light will turn off and the green arrow status light will turn on.
- c. Rotate the spindle arms to just past mid cycle and the green arrow status light will turn off and the red X status light turn back on.

8 CHANGE FROM FAIL SECURE TO FAIL SAFE or FAIL SAFE TO FAIL SECURE (IF REQUIRED)

- a. Disconnect the solenoid linkage (A) from the Solenoid by pulling out solenoid pin (X).
- b. Rotate Solenoid to line up with solenoid linkage (B) and reconnect Solenoid using solenoid pin (X).
- c. Disconnect the Pawl load spring (C) from the pawl pin (Y).
- d. Reconnect pawl load spring (C) to pawl pin (Z).
- e. On the Control Board that controls the Solenoid being changed, slide switch (S) to opposite position that it is in.

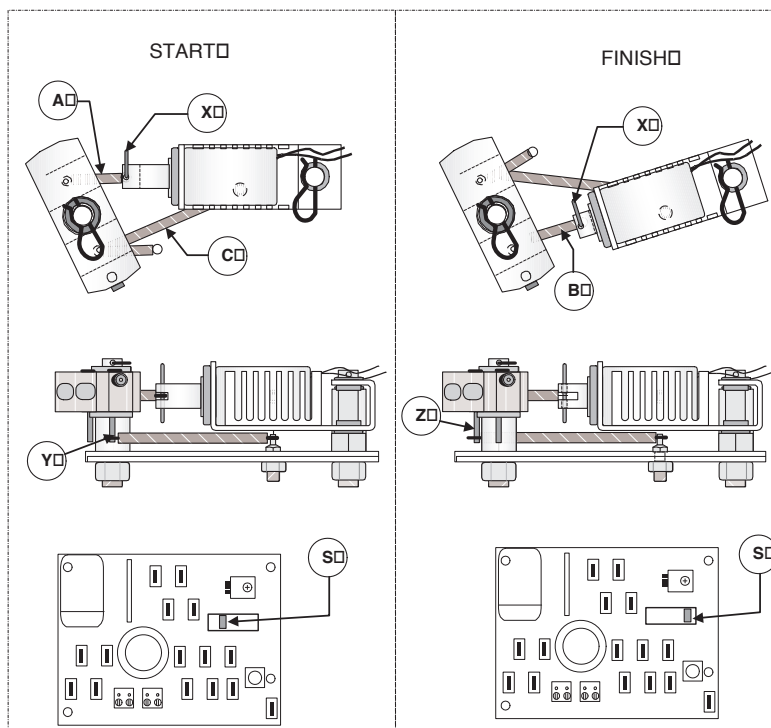

Figure 45 Conversion

CONNECTION DIAGRAM: FULL HEIGHT SECURITY TURNSTILE

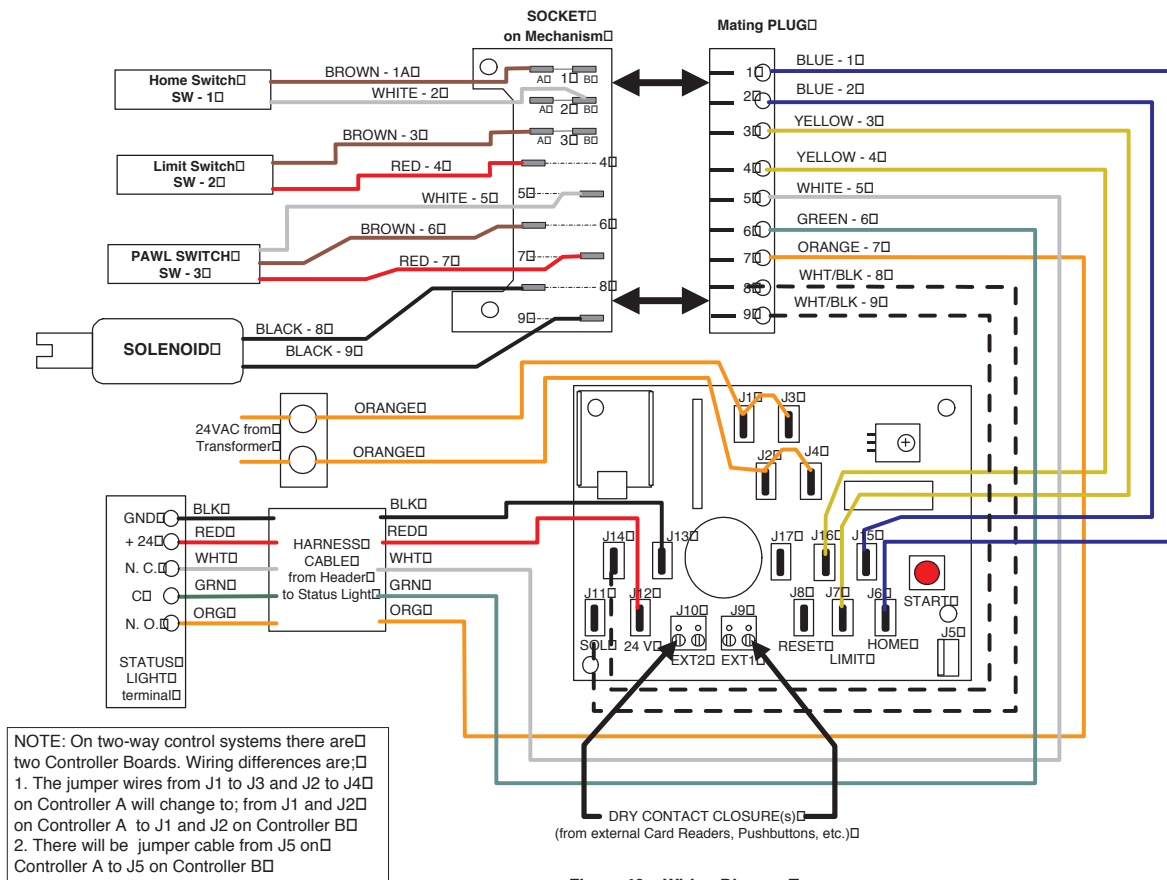

Figure 46 Wiring Diagram

SERVICE AND MAINTENANCE

- All bearings are self-lubricating and do not require servicing or lubrication.
- Annually check solenoid plungers for wear. If excessive wear is observed replace solenoid.
- Annually check mechanism self-centering and speed control cylinder by observing while rotation the spindle section.
- Annually check for loose bolts or nuts.

MECHANISM PARTS

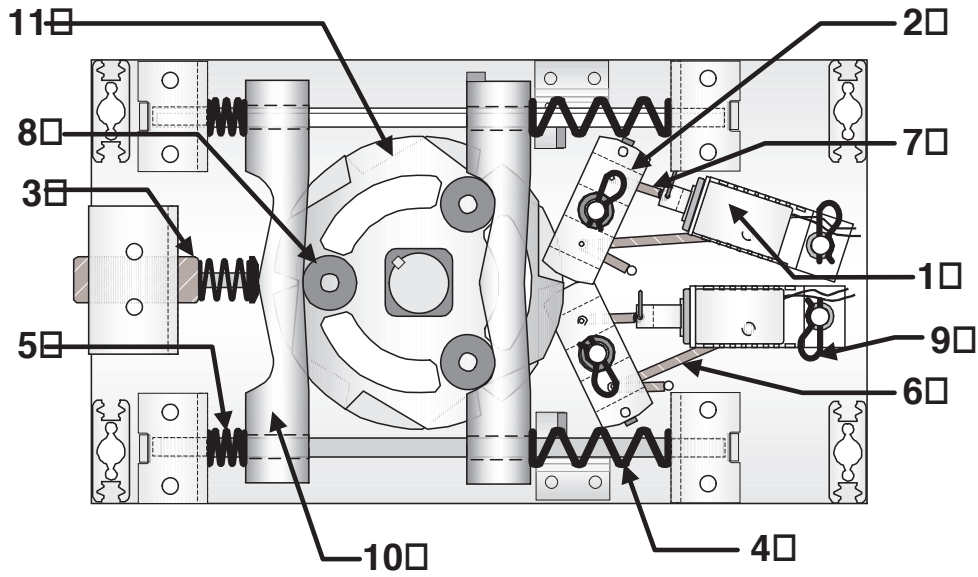

Figure 47 Mechanism Parts

Dwg #	Part Number	Description
1	315 4453 011	Solenoid Assembly
2	315 4383 001	Locking Pawl Assembly
3	315 4385 900	Shock Absorber
4	315 4396 910	Detent Centering Spring
5	315 4396 920	Detent Shock Spring
6	315 4397 910	Pawl Return Spring
7	315 4397 920	Solenoid to Pawl Spring
8	315 4417 001	Detent Cam Roller
9	315 4420 900	Hitch Pin Clip
10	315 4455 011	Detent Cam Assembly
11	315 4530 500	Ratchet and Bushing Assembly



mechtronics

©2010 Aigis Mechtronics

1124 Louise Road, Winston-Salem, NC 27107-5450

Tel: 336.785.7740 Fax: 336.785.7744

100 0253 001 AIG 01/10

Printed in U.S.A.

Data subject to change without notice

WWW.AIGISMECH.COM