

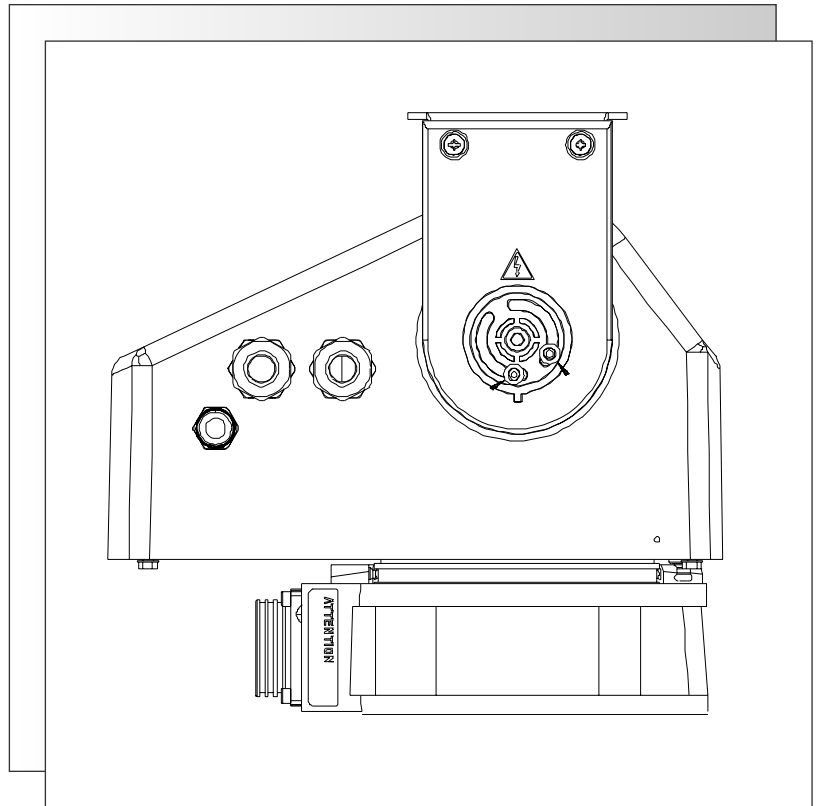

MEDIUM & HEAVY DUTY PAN/TILTS



**PT9418, PT9420
PT9440, PT9441**

IMPORTANT SAFEGUARDS



1. Read Instructions - All the safety and operating instructions should be read before the unit is operated.
 2. Retain Instructions - The safety and operating instructions should be retained for future reference.
 3. Heed Warnings - All warnings on the unit and in the operating instructions should be adhered to.
 4. Follow Instructions - All operating and use instructions should be followed.
 5. Cleaning - Unplug the unit from the outlet before cleaning. Do not use liquid cleaners or aerosol cleaners. Use a damp cloth for cleaning.
 6. Attachments - Do not use attachments not recommended by the product manufacturer as they may cause hazards.
 7. Accessories - Do not place this unit on an unstable stand, tripod, bracket, or mount. The unit may fall, causing serious injury to a person and serious damage to the unit. Use only with a stand, tripod, bracket, or mount recommended by the manufacturer or sold with the product. Any mounting of the unit should follow the manufacturer's instructions and should use a mounting accessory recommended by the manufacturer.
-  An appliance and cart combination should be moved with care. Quick stops, excessive force, and uneven surfaces may cause the appliance and cart combination to overturn.
8. Ventilation - Openings in the enclosure, if any, are provided for ventilation, to ensure reliable operation of the unit, and to protect it from overheating. These openings must not be blocked or covered. This unit should not be placed in a built-in installation unless proper ventilation is provided or the manufacturer's instructions have been adhered to.
 9. Power Sources - This unit should be operated only from the type of power source indicated on the marking label. If you are not sure of the type of power supply you plan to use, consult your appliance dealer or local power company. For units intended to operate from battery power or other sources, refer to the operating instructions.
 10. Grounding or Polarization - This unit may be equipped with a polarized alternating-current line plug (a plug having one blade wider than the other). This plug will fit into the power outlet only one way. This is a safety feature. If you are unable to insert the plug fully into the outlet, try reversing the plug. If the plug should still fail to fit, contact your electrician to replace your obsolete outlet. Do not defeat the safety purpose of the polarized plug. Alternately, this unit may be equipped with a 3-wire grounding-type plug, a plug having a third (grounding) pin. This plug will only fit into a grounding-type power outlet. This is a safety feature. If you are unable to insert the plug into the outlet, contact your electrician to replace your obsolete outlet. Do not defeat the safety purpose of the grounding-type plug.
 11. Power Cord Protection - Power supply cords should be routed so that they are not likely to be walked on or pinched by items placed upon or against them, paying particular attention to cords and plugs, convenience receptacles, and the point

where they exit from the appliance.

12. Power Lines - An outdoor system should not be located in the vicinity of overhead power lines or other electric light or power circuits or where it can fall into such power lines or circuits. When installing an outdoor system, extreme care should be taken to keep from touching such power lines or circuits as contact with them might be fatal. U.S.A. models only - refer to the National Electrical Code Article 820 regarding installation of CATV systems.
13. Overloading - Do not overload outlets and extension cords as this can result in a risk of fire or electric shock.
14. Object and Liquid Entry - Never push objects of any kind into this unit through openings, as they may touch dangerous voltage points or short out parts that could result in a fire or electric shock. Never spill liquid of any kind on the unit.
15. Servicing - Do not attempt to service this unit yourself as opening or removing covers may expose you to dangerous voltage or other hazards. Refer all servicing to qualified service personnel.
16. Damage Requiring Service - Unplug the unit from the outlet and refer servicing to qualified service personnel under the following conditions:
 - a. When the power supply cord or plug is damaged.
 - b. If liquid has been spilled or objects have fallen into the unit.
 - c. If the unit has been exposed to rain or water.
 - d. If the unit does not operate normally by following the operating instructions. Adjust only those controls that are covered by the operating instructions, as an improper adjustment of other controls may result in damage and will often require extensive work by a qualified technician to restore the unit to its normal operation.
 - e. If the unit has been dropped or the cabinet has been damaged.
 - f. When the unit exhibits a distinct change in performance--this indicates a need for service.
17. Replacement Parts - When replacement parts are required, be sure the service technician has used replacement parts specified by the manufacturer or have the same characteristics as the original part. Unauthorized substitutions may result in fire, electric shock, or other hazards.
18. Safety Check - Upon completion of any service or repairs to this unit, ask the service technician to perform safety checks to determine that the unit is in proper operating condition.
19. Coax Grounding - If an outside cable system is connected to the unit, be sure the cable system is grounded. U.S.A. models only--Section 810 of the National Electrical Code, ANSI/NFPA No.70-1981, provides information with respect to proper grounding of the mount and supporting structure, grounding of the coax to a discharge unit, size of grounding conductors, location of discharge unit, connection to grounding electrodes, and requirements for the grounding electrode.
20. Lightning - For added protection of this unit during a lightning storm, or when it is left unattended and unused for long periods of time, unplug it from the wall outlet and disconnect the cable system. This will prevent damage to the unit due to lightning and power line surges.

SAFETY PRECAUTIONS:

This label may appear on the bottom of the unit due to space limitations.

	CAUTION RISK OF ELECTRIC SHOCK. DO NOT OPEN!	
CAUTION: TO REDUCE RISK OF ELECTRICAL SHOCK, DO NOT OPEN COVERS. NO USER SERVICEABLE PARTS INSIDE. REFER SERVICING TO QUALIFIED SERVICE PERSONNEL.		

 The lightning flash with an arrowhead symbol within an equilateral triangle is intended to alert the user to the presence of uninsulated "dangerous voltage" within the product's enclosure that may be of sufficient magnitude to constitute a risk of electric shock to persons.

 The exclamation point within an equilateral triangle is intended to alert the user to presence of important operating and maintenance (servicing) instructions in the literature accompanying the appliance.

SECURITE: En raison de limitation de place, cette étiquette peut être placée sur le dessous de l'appareil.

	ATTENTION RISQUE DE COUTION. NE PAS OUVRIR	
DANGER: POUR ÉVITER TOUT RISQUE D'ÉLECTROCUTION, NE PAS OUVRIR LE BOÎTIER. IL N'Y A PAS DE PIÈCES REMPLAÇABLES À L'INTÉRIEUR. POUR TOUTE RÉVISION, S'ADRESSER À UN TECHNICIEN SPÉCIALISÉ.		

 L'éclair fléché dans un triangle équilatéral, avertit l'utilisateur de la présence d'une "tension dangereuse" non isolée à l'intérieur de l'appareil et d'une valeur suffisante pour constituer un risque d'électrocution.

 Le point d'exclamation contenu dans un triangle équilatéral, avertit l'utilisateur de la présence, dans la documentation qui accompagne l'appareil, de consignes d'utilisation et de maintenance importantes.

SICHERHEITSVORKEHRUNGEN:

Aus Platzgründen kann diese Warnung auf der Unterseite des Gerätes angebracht sein.

	VORSICHT STROMSCHLAGEGFAHRI! BITTE NICHT ÖFFNEN!	
VORSICHT: UM EINEN ELEKTRISCHEN SCHLAG ZU VERMEIDEN, ABDECKUNG NICHT ENTFERNEN. WARTUNGEN ALLER ART QUALIFIZIERTEM PERSONAL ÜBERLASSEN.		

 Das Blitzsymbol im gleichseitigen Dreieck soll den Benutzer auf nicht isolierte "Hochspannung" im Gehäuse aufmerksam machen, die eventuell stark genug ist, um einen elektrischen Schlag zu verursachen.

 Das Ausrufezeichen im gleichseitigen Dreieck soll den Benutzer auf wichtige Bedienungs- und Wartungsanleitungen in der dem Gerät beigefügten Literatur aufmerksam machen.

PRECAUCIONES DE SEGURIDAD: Debido a limitaciones de espacio, esta etiqueta puede aparecer en la parte inferior de la unidad.

	PRECAUCION RIESGO DE CHOQUE ELÉCTRICO. NO ABRIR!	
PRECAUCION: PARA REDUCIR EL RIESGO DE CHOQUE ELÉCTRICO, FAVOR NO ABRIR LA CUBIERTA. ESTE EQUIPO NO CONSTA DE PIEZAS O PARTES QUE REQUIEREN SERVICIO O MANTENIMIENTO. PARA REPARACIONES FAVOR REFERIRSE A UN TÉCNICO CALIFICADO.		

 El símbolo representado por un relámpago con punta de flecha dentro de un triángulo equilátero, se muestra con el objetivo de alertar al usuario que existen "voltajes peligrosos" sin aislamiento, dentro de la cubierta de la unidad. Dichos voltajes pueden ser de tal magnitud que constituyen un riesgo de choque eléctrico a personas.

 El símbolo de exclamación dentro de un triángulo equilátero, se muestra con el objetivo de alertar al usuario de que instrucciones de operación y mantenimiento importantes acompañan al equipo.

CONTENTS

1	INSTALLATION	4
1.1	Model Designation	4
1.2	Recommended Mounting Equipment	4
1.3	Wall Mounting	4
1.4	Camera/Lens/Enclosure Mounting	4
1.5	Electrical Connections	5
1.6	Grounding Connection	5
1.7	Connector Assembly	5
1.8	Pan Stops (345° Models)	7
2	OPERATION	7
2.1	Manual Pan Operation (345° Models)	7
2.2	Auto-Pan Operation (345° Models)	7
2.3	Pan Stop Adjustment (345° Models)	7
2.4	Pan Operation (360° Models)	7
2.5	Tilt Stop Adjustment (All Models)	8
2.6	Pre-Position Models	8
3	WIRING DIAGRAMS	9
4	RECOMMENDED APPLICATIONS	11
5	DIMENSIONAL OUTLINE	11

UNPACKING

Unpack carefully. This is electro-mechanical equipment and should be handled with care.

Check for the following items:

- Model number of unit.
- 3/32-inch Allen wrench.

If an item appears to have been damaged in shipment, replace it properly in its carton and notify the shipper. If any items are missing, notify Aigis Mechntronics.

The shipping carton is the safest container in which the unit may be transported. Save it for possible future use.

SERVICE

If the unit ever needs repair service, the customer should contact Aigis Mectronics for return authorization and shipping instructions, 1-800-523-6500.

1 INSTALLATION

 THIS INSTALLATION SHOULD BE MADE BY A QUALIFIED SERVICE PERSON AND CONFORM TO ALL LOCAL CODES.

 ALWAYS DISCONNECT POWER TO UNIT AT CONTROLLER PRIOR TO CONNECTING OR DISCONNECTING PAN/TILT ELECTRICAL CONNECTOR. PAN/TILT TO BE MOUNTED AWAY FROM UNAUTHORIZED ACCESS [3 METERS (10 FEET) HIGH MINIMUM]

 THESE UNITS ARE DESIGNED FOR EITHER UPRIGHT OR INVERTED INSTALLATIONS. TO MAINTAIN WEATHER-PROOF INTEGRITY WHEN MOUNTING OUTDOORS IN AN INVERTED POSITION, THE UNIT MUST BE INSTALLED IN A WEATHERPROOF ENCLOSURE (E.G., WEATHER-PROOF DOMED HOUSING) OR A PROTECTED OUTSIDE AREA.

Pan/tilts and associated equipment should be tested prior to field installation to verify proper wiring and operation of components.

PT9418 & 9420:

The maximum load is 10 kg (22 lb) or 149 kg-cm (129lb-in) torque at a distance of 63.5 mm (2.5 in) from the center of mass of the camera/lens/housing assembly to the center of the tilt table.

PT9440 & PT9441

The maximum load is 18kg (40lb) or 297 kg-cm (260in-lb) torque with center of mass located 3.12 in (79.2 mm) from the center of the title table.

The combined weight of the enclosure/camera/lens should be centered equally, front to back, on the tilt table surface for best pan/tilt operation.

SEE RECOMMENDED APPLICATIONS.

1.1 Model Designation

PT9418 Series	Load Rating: 22lb Load (10Kg), 129lb-in (149 kg-cm) torque
	Wiring: Standard Power Required: 24W
PT9420 Series	Load Rating: 22lb Load (10Kg), 129lb-in (149 kg-cm) torque
	Wiring: Feed-thru Power Required: 24W
PT9440 Series	Load Rating: 40lb Load (18kg), 260lb-in (297 kg-cm) torque
	Wiring: Standard Power Required: 20W
PT9441 Series	Load Rating: 40lb Load (18kg), 260lb-in (297 kg-cm) torque
	Wiring: Feed-thru Power Required: 20W

	Rated Motor Voltage	Voltage Range
-6 models:	110VAC, 60Hz	108 to 132
-2 models:	24VAC, 60Hz	21.6 to 26.4
* 40lb Models	24VAC, 60Hz	23 to 26.4
-1 models:	24VAC, 50Hz	21.6 to 26.4
-5 models:	220VAC, 50Hz	207 to 253

Pan Range: 0° to 345° on standard models, 0° to 360° on -SL versions. Preposition is designated with a -P

 CAUTION: DO NOT EXCEED 30 VAC INPUT ON 24 VAC MODELS. OPERATION ABOVE 30 VAC VIOLATES LOW VOLTAGE OPERATION (CLASS 2 SPECIFICATIONS). NORMAL OPERATION IS 24 VAC. CUL APPROVED 24 VAC MODELS.

 CAUTION: CONNECT TO CLASS 2 POWER SUPPLY ONLY. TOTAL CURRENT THROUGH ELECTRICAL CONNECTOR IS 4 A MAXIMUM. PAN/TILT CURRENT IS 1 A MAXIMUM. ALLOWABLE CAMERA/HOUSING IS 3 A MAXIMUM. USE ONLY 24 VAC CAMERAS AND HOUSINGS ON FEED-THRU MODELS.

1.2 Recommended Mounting Equipment

MT9216	Medium duty wall mount designed to support up to 45.3 kg (100 lb).
MT9222	Heavy duty wall mount designed to support up to 90.6 kg (200 lb).
MT9214	Heavy duty 336 mm (14 inch) column mount for ceiling or pedestal.
MT9224	Heavy duty 610 mm (24 inch) column mount for ceiling or pedestal use.

1.3 Wall Mounting

Follow the instructions provided with mounts. Mount and mounting surface must be able to support the weight of the pan/tilt, camera/lens, and enclosure (if used). The camera/lens/enclosure must be properly mounted and balanced on the pan/tilt bracket.

 CAUTION: THE PAN/TILTS IN THIS MANUAL CAN ONLY BE MOUNTED UPRIGHT OR INVERTED; NEVER HORIZONTALLY.

1.4 Camera/Lens/Enclosure Mounting

Mount the camera/lens/enclosure to the pan/tilt bracket as follows:

1. Balance the camera/lens/enclosure and adjust unit to align with mounting holes. Fasten with a minimum of two (2) 1/4-20 x 1/2-inch long fasteners and lock washers.
2. Make all electrical connections. Leave sufficient loops of cable between camera/enclosure and pan/tilt to allow for tilting and panning.

1.5 Electrical Connections

1. Cable must be wired according to Connector Assembly and Recommended Maximum Cable Lengths.
2. Use separate shielded cables for camera power, enclosure power, and pan/tilt control. If required, combining lens control wiring and video coax within a common cable is acceptable. The use of a common multiconductor cable to combine all functions is not recommended.
3. Use color coded conductors to aid wiring and future identification.
4. Retain wiring diagram for later reference.

Model Voltage	Wire Size		Distance	
	mm ²	AWG	Feet	Meters
24 VAC	0.5	20	140	43
	1	18	230	70
	1.5	16	360	110
	2.5	14	590	180
	4	12	940	287
110 VAC	0.5	20	2200	671
	1	18	3500	1067
	1.5	16	5500	1677
	2.5	14	9000	2744
220 VAC	0.5	20	13400	4085
	1	18	21200	6463
	1.5	16	33300	10152
	2.5	14	54400	16585

1. Values calculated at 20 °C (68 °F) using stranded tinned copper wire, a common ground (neutral), and with both PAN and TILT motors operating simultaneously.

AMP Hand Crimping Tool #58495-1 is recommended for crimping of sockets. Model listings on the following page detail the electrical connections required. Refer to **Figure 2: Wiring Instructions** for the numbered connector positions.

The connector will accept up to a #16 AWG wire. If heavier gauge wire is required, pigtail according to local electrical codes is recommended.

CAUTION: CONTACT REMOVAL FROM CONNECTOR REQUIRES USE OF AMP #305183 EXTRACTION TOOL.

1.6 Grounding Connection

A ground screw is located on the base to the right of connector. See DIMENSIONAL OUTLINE. Connect a 1 mm² (No.18 AWG) ground wire to the nearest earth ground.

1.7 Connector Assembly

A mating connector, sockets and a strain relief are included with the unit. See Figure 1: Shield/Strain Relief Assembly.

To install, select the appropriate size strain relief clamp. Choose one of the two strain relief clamps enclosed with the sleeve and the extender. The clamping area is adjustable by inverting or changing the strain relief clamps. Discard the four strain reliefs on the carrier strip packaged with the shield.

Insert the clamp into the strain relief until it bottoms. The clamp should bottom on the wire bundle, not on the shield's shoulder. If the wire diameter is too small, temporarily wrap the wire with electrical tape until proper clamping is obtained. Secure the clamp with the two (2) screws provided.

CAUTION: MAKE SURE THE WIRE BUNDLE IS PROPERLY SECURED. DO NOT PINCH THE WIRES.

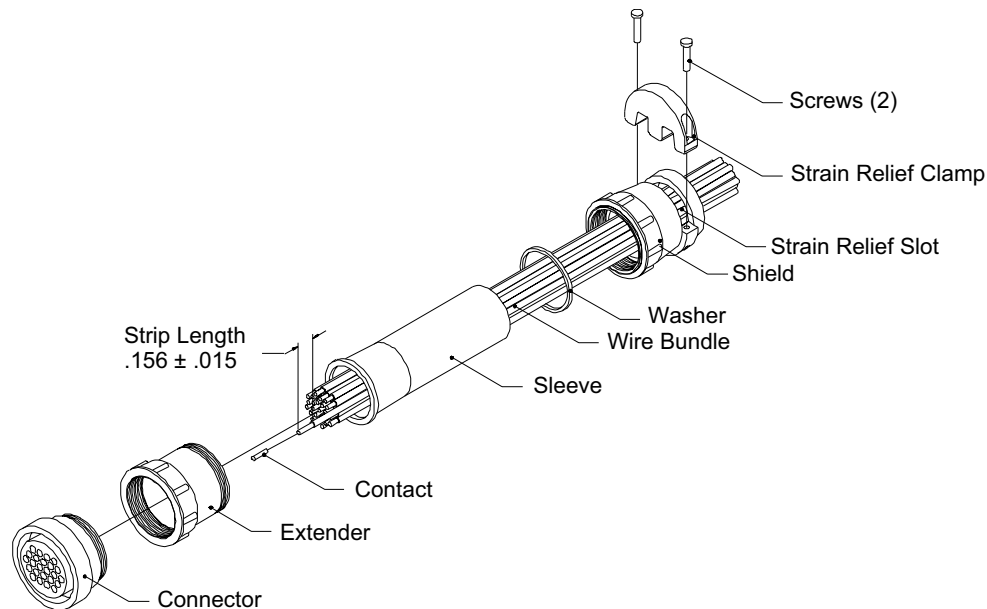

Figure 1: Shield/Strain Relief Assembly

WIRE DESIGNATION AND PIN CONNECTIONS

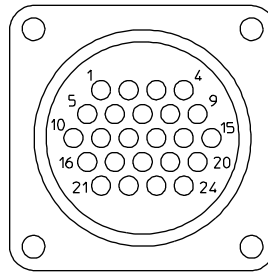

Figure 2: Pin OUTs

345° Non-Pre-Position Models^{5,6} Feed-thru Wiring

Pin Number	Color
1: NC ¹	
2: NC ¹	
3: NC ¹	
4: NC ¹	
5: Lens Common	Green ²
6: Zoom	Blue ²
7: Focus	Violet ²
8: Unused	Brown ²
9: Unused	Black ²
10: Accessory	White ^{2,3}
11: Accessory	Red ^{2,3}
12: Accessory	Yellow ^{2,3}
13: NC ¹	
14: NC ¹	
15: NC ¹	
16: Pan Left	White
17: NC ¹	
18: Pan Right	Violet
19: P/T Common	Blue
20: Tilt Up	Brown
21: Tilt Down	White/Yellow
22: Ground	Green/Yellow ²
23: Camera AC-Line	Black ^{2,4}
24: Camera AC-Neutral	White ^{2,4}

345° Non-Pre-Position Models^{5,6} Standard Wiring

Pin Number	Color
1: NC ¹	
2: NC ¹	
3: NC ¹	
4: NC ¹	
5: NC ¹	
6: NC ¹	
7: NC ¹	
8: NC ¹	
9: NC ¹	
10: NC ¹	
11: NC ¹	
12: NC ¹	
13: NC ¹	
14: NC ¹	
15: NC ¹	
16: Pan Left	White
17: NC ¹	
18: Pan Right	Violet
19: P/T Common	Blue
20: Tilt Up	Brown
21: Tilt Down	White/Yellow
22: Ground	Green/Yellow ²
23: NC ¹	
24: NC ¹	

360° Pre-Position & Non-Preposition Models^{7,8} Feed-thru Wiring

Pin Number	Color
1: Pan +5V	Orange
2: Pan Sense (3)	Wht/Blk/Yel ⁸
3: Pan -5V	Wht/Blk/Red ⁸
4: Tilt Sense	Wht/Blk/Brm ⁸
5: Lens Common	Green ²
6: Zoom	Blue ²
7: Focus	Violet ²
8: NC ¹	
9: NC ¹	
10: Accessory	White ^{2,3}
11: Accessory	Red ^{2,3}
12: Accessory	Yellow ^{2,3}
13: NC ¹	
14: NC ¹	
15: Pan Sense (2)	White/Orange ⁸
16: Pan Left	White
17: NC ¹	
18: Pan Right	Violet
19: P/T Common	Blue
20: Tilt Up	Brown
21: Tilt Down	White/Yellow
22: Ground	Green/Yellow ²
23: Camera AC-Line	Black ²
24: Camera AC-Neutral	White ²

345° Pre-Position Models^{5,6} Feed-thru Wiring

Pin Number	Color
1: PP Supply (+)	Orange ²
2: Pan Position	Yellow ²
3: PP Return (-)	Gray ²
4: Tilt Position	White/Black ²
5: Lens Common	Green ²
6: Zoom	Blue ²
7: Focus	Violet ²
8: Zoom Position	Brown ²
9: Focus Position	Black ²
10: Accessory	White ^{2,3}
11: Accessory	Red ^{2,3}
12: Accessory	Yellow ^{2,3}
13: NC ¹	
14: NC ¹	
15: NC ¹	
16: Pan Left	White
17: NC ¹	
18: Pan Right	Violet
19: P/T Common	Blue
20: Tilt Up	Brown
21: Tilt Down	White/Yellow
22: Ground	Green/Yellow ²
23: Camera AC-Line	Black ^{2,4}
24: Camera AC-Neutral	White ^{2,4}

345° Pre-Position Models^{5,6} Standard Wiring

Pin Number	Color
1: PP Supply (+)	Orange ²
2: Pan Position	Yellow ²
3: PP Return (-)	Gray ²
4: Tilt Position	White/Black ²
5: NC ¹	
6: NC ¹	
7: NC ¹	
8: NC ¹	
9: NC ¹	
10: NC ¹	
11: NC ¹	
12: NC ¹	
13: NC ¹	
14: NC ¹	
15: NC ¹	
16: Pan Left	White
17: NC ¹	
18: Pan Right	Violet
19: P/T Common	Blue
20: Tilt Up	Brown
21: Tilt Down	White/Yellow
22: Ground	Green/Yellow ²
23: NC ¹	
24: NC ¹	

Notes

1. NC -- No Connection, do not use.
2. (Color Codes) indicate feed-thru wiring to camera/housing.
3. Apply to 24 volt models only. Pins 10 thru 12 are not used in 110 volt or 220 volt models.
4. (Color Codes) shown are for 24 volt, 60 HZ and 110 volts models. For 220 volt and 24 volt, 50 HZ models, color codes are (23) Brown, and (24) Blue.
5. The conductors for pins 16 thru 24 (where applicable) on 220 volt models should be isolated from other wiring with reinforced insulation requirements of DIN VDE 0860/05.89, IEC 65, 1985. The conductors for pins 16 thru 24 (where applicable) must be in HAR cord minimum cross sectional area 0.75 mm² (H05 VV-F).
6. Refer to **Figure 6** under Wiring Diagrams for the wiring schematic.
7. Refer to **Figure 7** under Wiring Diagrams for the wiring schematic.
8. Pre-Position models only. Refer to **Figure 8** for the wiring schematic.

1.8 Pan Stops (345° Models)

Locate the three (3) limit stops on the base of the unit. The red limit stop is the Fixed Stop. It is not adjustable and should not be removed. The remaining two (2) stops are called the Pan Stops. These are positioned on each side of the pan switch lever.

The two (2) pan stops are adjustable and secured with a set screw. The screws can be accessed through the hole in the end of each stop. Use a 3/32-inch Allen wrench (supplied) to loosen and tighten the set screw. See **Figure 3: Pan Stop Locations (345° Models)**.

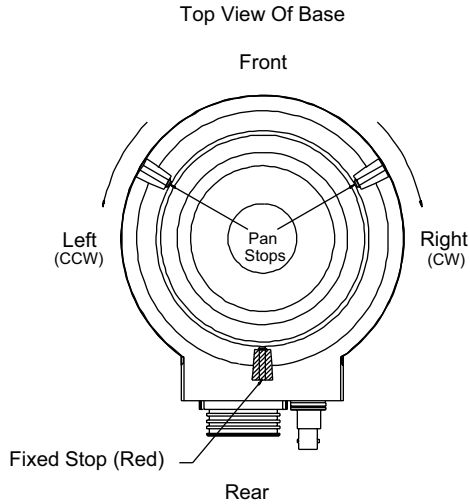



Figure 3: Pan Stop Locations (345° Models)

2 OPERATION

2.1 Manual Pan Operation (345° Models)

The pan stops establish the limits for manual pan. The two (2) adjustable pan stops may be repositioned or removed depending on the desired operation. The maximum pan range setup is shown in Figure 4: Maximum Manual Pan and Maximum Auto-Pan (345° Models).

 **Caution:** Never move or remove the fixed stop. It must always be in place for proper operation of the pan function.

2.2 Auto-Pan Operation (345° Models)

Use of the auto-pan function requires wiring connections to pin 16 (Pan Left), pin 18 (Pan Right), and pin 19 (Common). See **Figure 6: Wiring Diagram (0° - 345° Models)**. The auto-pan function is achieved by the controller unit sensing changes in current flow through the pan motor. When a pan stop is reached, the current flow stops and internal circuitry of the controller unit reverses the auto-pan direction.

Note: The pan/tilt controller must be equipped with special current sensing circuitry to operate the auto-pan function in this mode. The pan stops or the fixed stop establish the limits for auto-pan.

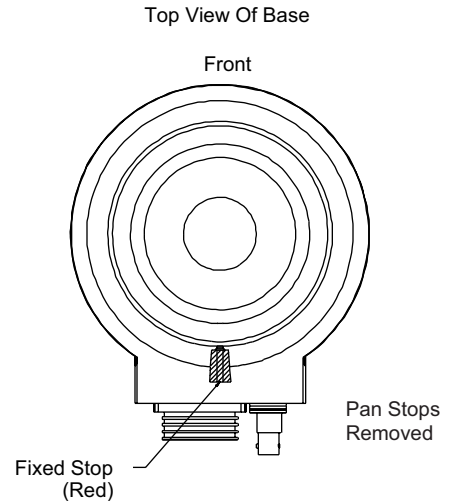

Figure 4: Maximum Manual Pan and Maximum Auto-Pan (345° Models)

2.3 Pan Stop Adjustment (345° Models)

1. Loosen the pan stops and adjust to the desired range for manual pan and auto-pan. A recessed area in the pan head allows enough clearance to remove a stop from the base.
2. When all the stops are in place, check to see that they are secure.
3. Operate the unit from the controller to confirm that the limits are set properly. Readjust if required.

2.4 Pan Operation (360° Models)

These models allow 360 degree rotational (pan) operation. They have no pan stops. These units can be manually panned left or right or they can be panned continuously left or right by auto-pan activation. Auto-Pan activation requires wiring connections to pin 16 (Pan Left), pin 18 (Pan Right), and pin 19 (Common). See **Figure 7: Wiring Diagram (360° Models)**.

2.5 Tilt Stop Adjustment (All Models)

After the unit is installed and all wire connections are made, apply proper power to the control unit. Refer to **Figure 5: Tilt Stops (Side View - Plug Removed)** and adjust the tilt stops as follows:

1. With the front of the pan/tilt facing you, remove the left hub cap. The tilt stop adjustment screws are now exposed.
2. Using the control unit, tilt the bracket up to the desired position and stop the unit. Use the 3/32-inch Allen wrench to loosen the Tilt Up stop. Slide the stop Up until a faint click is heard (indicating switch actuation). Tighten the Tilt Up limit stop screw.
3. Using the control unit, tilt the bracket to the desired position and stop the unit. Use the 3/32-inch Allen wrench to loosen the Tilt Down stop. Slide the stop Down until a faint click is heard. Tighten the Tilt Down limit stop screw.
4. Operate the control unit to verify proper tilt stop range and operation. Repeat above sequence if necessary. Make certain both tilt stop screws are snug. Replace the hub cap.

 **CAUTION: DO NOT OPERATE PAN/TILT UNIT WITHOUT STOPS. LIMIT STOPS SHOULD NOT BE ADJUSTED WHILE UNIT IS OPERATING.**

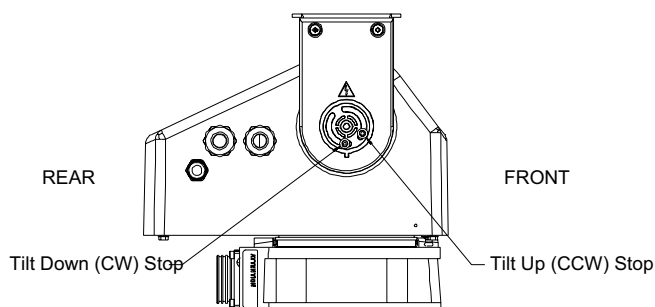

Figure 5: Tilt Stops (Side View - Plug Removed)

2.6 Pre-Position Models

The 345° models with pre-position capability have "P" suffix in the model number. These models require wiring connections to pins 1 through 4, 8 and 9, and the use of a controller or receiver/driver with the pre-position function. Pan and tilt operation and limit stop adjustments function the same as the previous models described.

3. WIRING DIAGRAMS

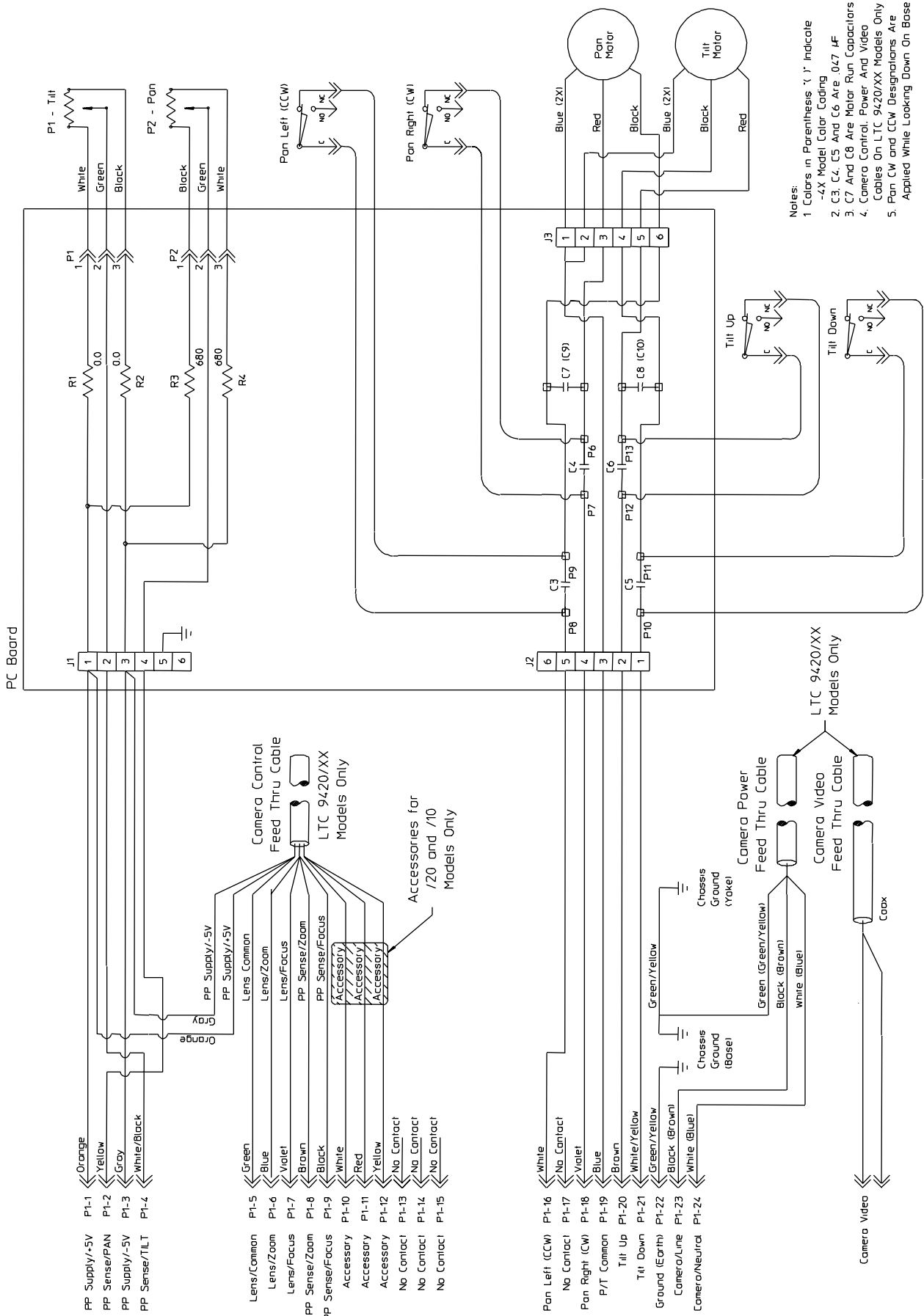

Figure 6: Wiring Diagram - 0° to 345° Models

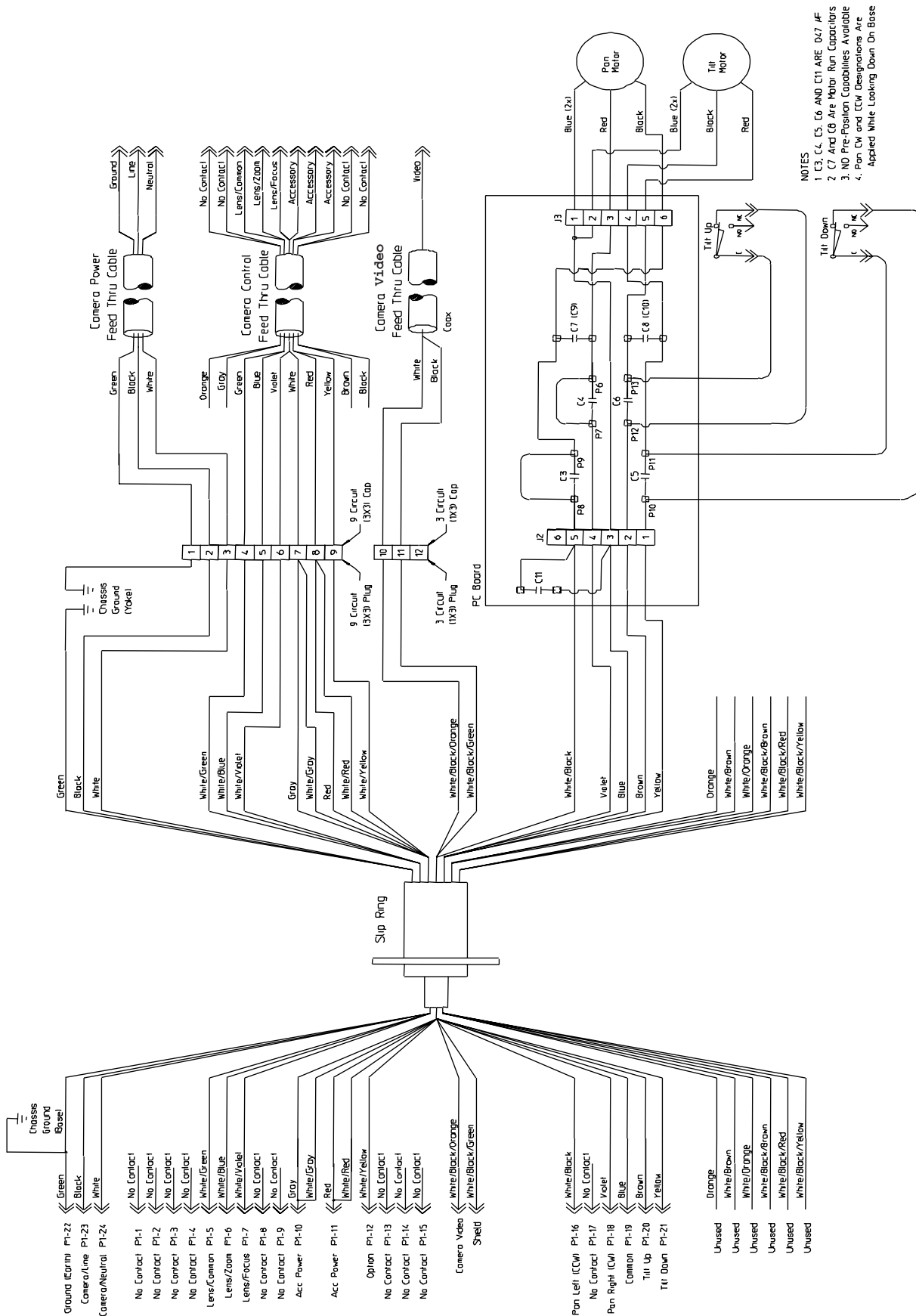

Figure 7: Wiring Diagram - 360° Models

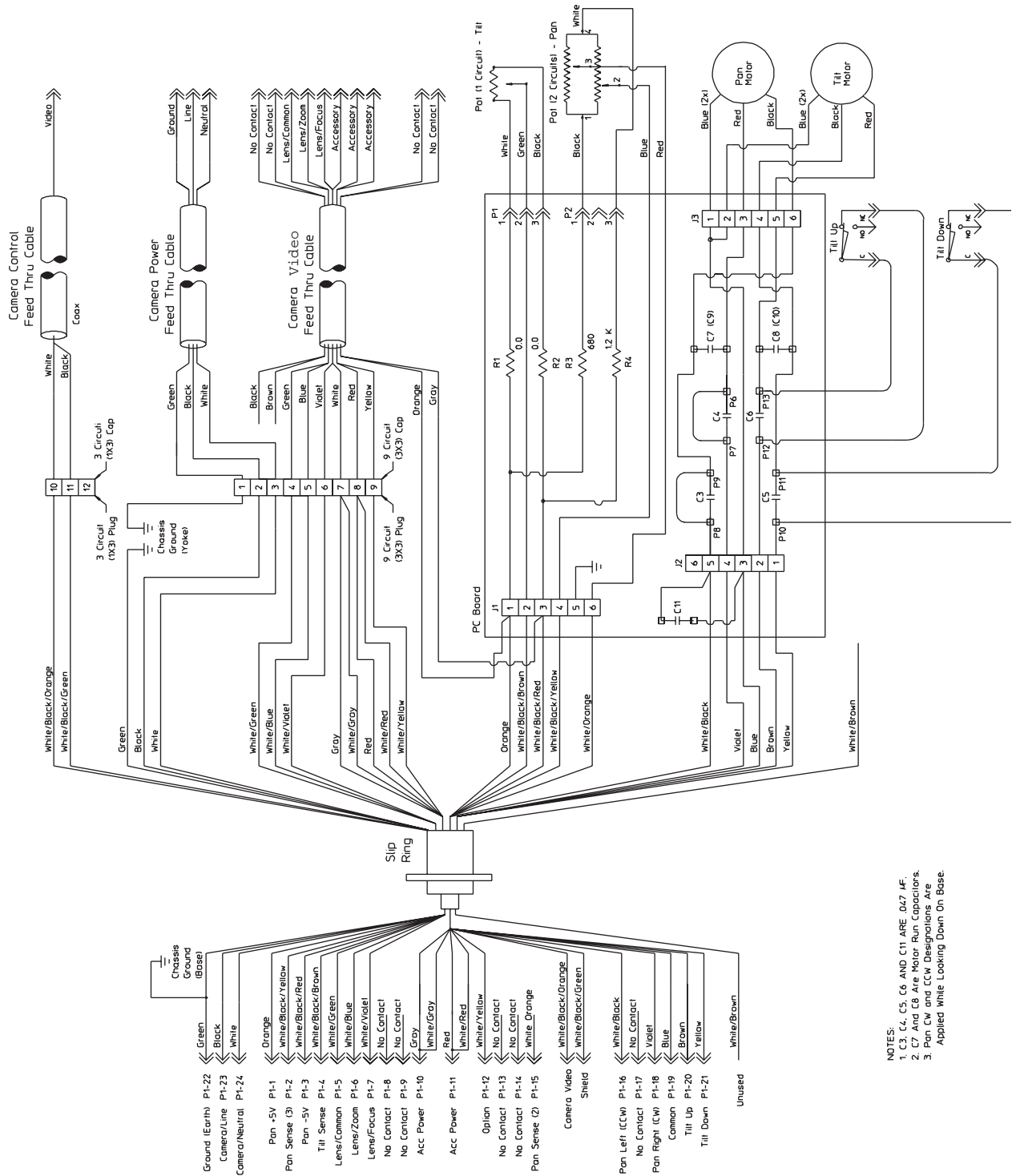



Figure 8: Wiring Diagram - 360° Models with Pre-Position

4 RECOMMENDED APPLICATIONS

360° Models Only

 USE ONLY 24 VOLT CAMERAS/HOUSINGS WITH 360° MODEL PAN/TILTS.

 THE MAXIMUM POWER FOR HEATER/BLOWER COMBINATIONS IS 75 WATTS TO PREVENT OVERLOADING THE SLIP RING. THIS LOAD MUST BE POWERED BY PIN 10, (WHITE FEED-THRU) AND PIN 11 (RED FEED-THRU). SEE FIGURE 1: WIRING INSTRUCTIONS.

Feed-thru 24 Volt Models

 TO MAINTAIN CUL AND TUV APPROVAL, USE ONLY 24 VOLT CAMERAS/HOUSINGS.

5 DIMENSIONAL OUTLINE

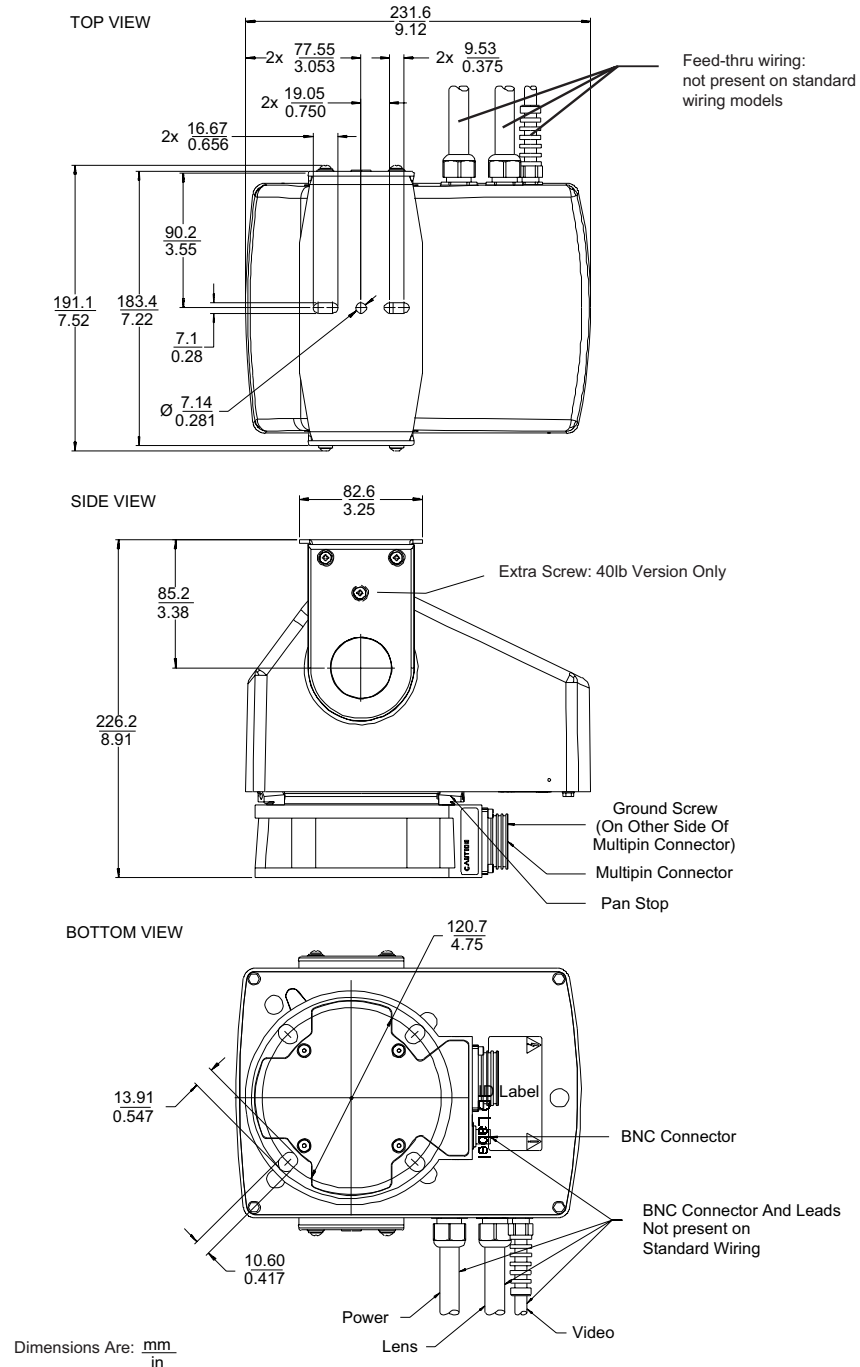
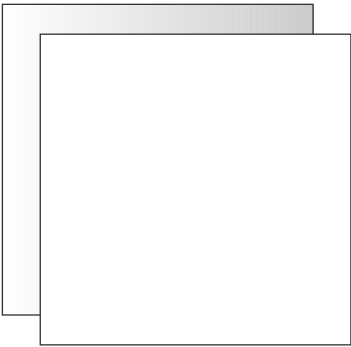

Figure 9



mechtronics

©2002 Aigis Mechtronics, LLC

1124 Louise Road, Winston-Salem, NC 27107-5450

Tel: 336.785.7740 Fax: 336.785.7744

www.Aigismech.com

Data subject to change without notice

100 0047 002 AIG 08/03

Printed in U.S.A.