



**CRYSTALVUE™
PUBLIC VIEW DISPLAY (PVD)**

PVDxxA Series

**INSTALLATION AND OPERATING INSTRUCTIONS
WWW.AIGISMECH.COM**

IMPORTANT SAFEGUARDS



ATTENTION – Observe Precautions For Handling Electrostatic Sensitive Devices

1. Read Instructions - All the safety and operating instructions should be read before the unit is operated.
2. Retain Instructions - The safety and operating instructions should be retained for future reference.
3. Heed Warnings - All warnings on the unit and in the operating instructions should be adhered to.
4. Follow Instructions - All operating and use instructions should be followed.
5. Cleaning - Unplug the unit from the outlet before cleaning. Do not use liquid cleaners or aerosol cleaners. Use a damp cloth for cleaning.
6. Attachments - Do not use attachments not recommended by the product manufacturer as they may cause hazards.
7. Accessories - Do not place this unit on an unstable stand, tripod, bracket, or mount. The unit may fall, causing serious injury to a person and serious damage to the unit. Use only with a stand, tripod, bracket, or mount recommended by the manufacturer or sold with the product. Any mounting of the unit should follow the manufacturer's instructions and should use a mounting accessory recommended by the manufacturer.
8. Ventilation - Openings in the enclosure, if any, are provided for ventilation, to ensure reliable operation of the unit, and to protect it from overheating. These openings must not be blocked or covered. This unit should not be placed in a built-in installation unless proper ventilation is provided or the manufacturer's instructions have been adhered to.
9. Power Sources - This unit should be operated only from the type of power source indicated on the marking label. If you are not sure of the type of power supply you plan to use, consult your appliance dealer or local power company. For units intended to operate from battery power or other sources, refer to the operating instructions.
10. Grounding or Polarization - This unit may be equipped with a polarized alternating-current line plug (a plug having one blade wider than the other). This plug will fit into the power outlet only one way. This is a safety feature. If you are unable to insert the plug fully into the outlet, try reversing the plug. If the plug should still fail to fit, contact your electrician to replace your obsolete outlet. Do not defeat the safety purpose of the polarized plug. Alternately, this unit may be equipped with a 3-wire grounding-type plug, a plug having a third (grounding) pin. This plug will only fit into a grounding-type power outlet. This is a safety feature. If you are unable to insert the plug into the outlet, contact your electrician to replace your obsolete outlet. Do not defeat the safety purpose of the grounding-type plug.
11. Power Cord Protection - Power supply cords should be routed so that they are not likely to be walked on or pinched by items placed upon or against them, paying particular attention to cords and plugs, convenience receptacles, and the point where they exit from the appliance.
12. Power Lines - An outdoor system should not be located in the vicinity of overhead power lines or other electric light or power circuits or where it can fall into such power lines or circuits. When installing an outdoor system, extreme care should be taken to keep from touching such power lines or circuits as contact with them might be fatal. U.S.A. models only - refer to the National Electrical Code Article 820 regarding installation of CATV systems.
13. Overloading - Do not overload outlets and extension cords as this can result in system failure.
14. Object and Liquid Entry - Never push objects of any kind into this unit through openings, as they may touch dangerous voltage points or short out parts that could result in a fire or electric shock. Never spill liquid of any kind on the unit.
15. Servicing - Do not attempt to service this unit yourself as opening or removing covers may expose you to dangerous voltage or other hazards. Refer all servicing to qualified service personnel.
16. Damage Requiring Service - Unplug the unit from the outlet and refer servicing to qualified service personnel under the following conditions:
 - a. When the power supply cord or plug is damaged.
 - b. If liquid has been spilled or objects have fallen into the unit.
 - c. If the unit has been exposed to rain or water.
 - d. If the unit does not operate normally by following the operating instructions. Adjust only those controls that are covered by the operating instructions, as an improper adjustment of other controls may result in damage and will often require extensive work by a qualified technician to restore the unit to its normal operation.
 - e. If the unit has been dropped or the cabinet has been damaged.
 - f. When the unit exhibits a distinct change in performance--this indicates a need for service.
17. Replacement Parts - When replacement parts are required, be sure the service technician has used replacement parts specified by the manufacturer or have the same characteristics as the original part. Unauthorized substitutions may result in fire, electric shock, or other hazards.
18. Coax Grounding - If an outside cable system is connected to the unit, be sure the cable system is grounded. U.S.A. models only--Section 810 of the National Electrical Code, ANSI/NFPA No.70-1981, provides information with respect to proper grounding of the mount and supporting structure, grounding of the coax to a discharge unit, size of grounding conductors, location of discharge unit, connection to grounding electrodes, and requirements for the grounding electrode.

What is Electrostatic Discharge?

A transfer of electrostatic charges between bodies at different electrostatic potentials caused by direct contact or induced by an electrostatic field. The following are some examples of electrostatic charges:

1. Walking across a nylon carpet on a dry day generates a static electrical charge of 35,000 volts.
2. Opening a plastic bag generates a charge of 20,000 volts.



Warning: In a domestic environment, this product may cause radio interference in which case the user may be required to take adequate measures.



WARNING: Do not make repairs yourself. Do Not attempt to remove the cover to the CrystalVue™. Do Not disassemble it or remove any parts. You run the risk of electric shock and voiding the warranty. No user-serviceable parts are inside.

SAFETY PRECAUTIONS



CAUTION: TO REDUCE THE RISK OF ELECTRICAL SHOCK, DO NOT OPEN COVERS. NO USER SERVICEABLE PARTS INSIDE. REFER SERVICING TO QUALIFIED SERVICE PERSONNEL.

This label may appear on the bottom of the unit due to space limitations.



The lightning flash with an arrowhead symbol within an equilateral triangle is intended to alert the user to the presence of uninsulated "dangerous voltage" within the product's enclosure that may be of sufficient magnitude to constitute a risk of electric shock to persons.



The exclamation point within an equilateral triangle is intended to alert the user to presence of important operating and maintenance (servicing) instructions in the literature accompanying the appliance.

1. UNPACKING

Unpack carefully. This is an electromechanical device and should be handled carefully. Remove all of the items from the box. It is recommended that you do not remove the clear protective plastic covers on the CrystalVue™ at this time. Check to ensure that the following items are included:

- CrystalVue™ Public View Display: LCD Monitor
- Remote Control

2. SERVICE

If the unit needs repair service or parts, contact Aigis Mechtronics for authorization to return as well as shipping instructions.

3. DESCRIPTION

The Standard Security (N)* CrystalVue™ PVDxxA consists of an LCD monitor and a built in CCTV camera and light sensor. The system is capable of looping video and operates with a Low Voltage AC or 110 VAC/60Hz power supply. The IR remote control and on-screen display provide easy setup and monitor control.

Construction/Finish: Fabricated aluminum case.

*Additional features available are sold in a series of Feature Sets see the descriptions below for your unit.

Feature Set Designation

With so many features to choose from Aigis has created a series of “Feature Sets” that combine our most popular CrystalVue™ options into easy to order groupings. All CrystalVue™ units come standard with a remote control, a light sensor, and looping capabilities. See Model Designation next page to determine the feature set of your model if you are uncertain.

Security (N)

This basic feature set creates instant awareness by showing the viewer his or her own image on screen using the **Built in Camera**. The on screen video is looped back to a monitoring station or sent to a video recording device such as a DVR. CrystalVue™ is set up via the On Screen Display Menus using the **Remote Control**. Set the **Light Sensor** to switch over to power save mode upon a pre-set change in lighting conditions, extending screen life.

Security/Marketing (MP)

This feature set includes the Security (N) features plus a **Motion Detector**, **Picture-in Picture** abilities and adds one additional **Composite Input** and an **additional Composite Output**. By adding these capabilities this loss prevention tool now doubles as a powerful marketing device. Use this version of CrystalVue™ to show video messages and company logos, run advertisements, and get your message out. By using the Motion Detector feature CrystalVue™ will switch to the surveillance image upon motion for a set dwell rate. Adding the additional composite input now allows the Light Sensor to switch to either power save or another form of video upon a preset change in ambient light. The picture-in-picture settings further enhance these features by allowing both video images to be viewed on screen simultaneously.

Security/On Board Marketing (FMP)

This feature set includes all the Security (N) and Security/Marketing (MP) features plus provides a built in compact **Flash Card Reader**. This feature enhances the flexibility of the marketing capabilities by allowing a preloaded presentation such as a JPEG slide show, to play continuously on the CrystalVue™. The Flash Card Reader supports 7 kinds of Media Cards and 7 forms of electronic file types providing flexibility and easy access for updating the on board presentations.

Full Featured (AFMP)

This feature set includes all the Security (N), Security/Marketing (MP) and Security/On Board Marketing (FMP) features plus **Audio** and one more **External Video Input** bringing the total external inputs to two. Configure it any way you like, choose to connect two external devices and switch the video between them plus add sound to draw attention to the on-screen video.

Additional Options, this model only:

- External Digital Video Input (DVI) for ultra high definition resolution.
- External VGA Input

No Camera

No Camera Versions of the CrystalVue™ can be included in any of the Feature Sets, the difference would be the exclusion of the built in CCTV camera. The no camera versions come standard with one external video input and output.

CRYSTALVUE™ MODEL DESIGNATION

To verify the part number and Feature Set use the following chart.

Example Part Number
PVD20A-CH36MP-W-A

Choose One

Monitor Size

Part Number

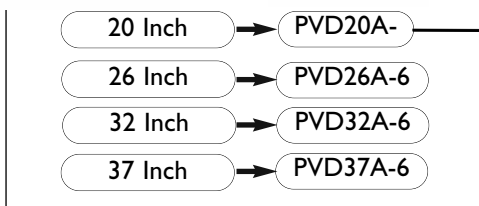

Choose One

Camera Type

Part Number

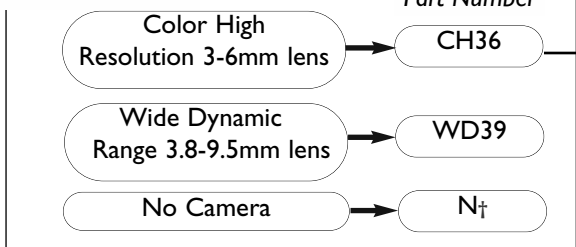

Choose One

Feature Set**

Part Number

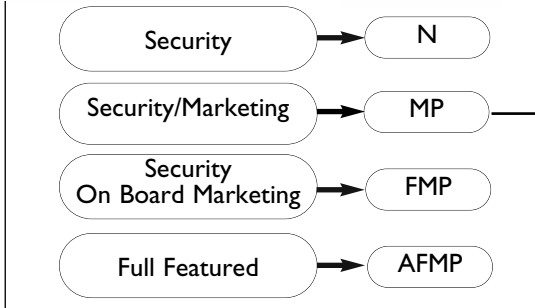

Choose One

Color

Part Number

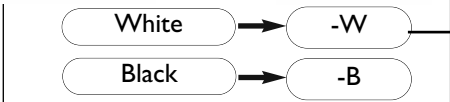

Choose

Network (Optional)

Part Number

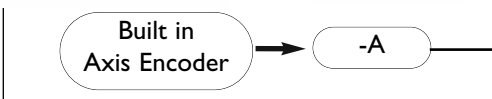

**Feature Sets

All CrystalVue™ PVD Systems come standard with a Light Sensor, Remote Control and Amplified Video Outputs.†

Security (N)† - (1) One Composite Video Output

Security/Marketing (MP)† - Motion Detector, Picture-In-Picture, (1) One External Composite Video Input, (2) Two Composite Video Outputs

Security/On Board Marketing (FMP)† - Built in Flash Card Reader, Motion Detector, Picture-In-Picture, (1) One External Composite Video Input, (2) Two Composite Video Outputs

Full Featured (AFMP) - Audio, Built in Flash Card Reader, Motion Detector, Picture-In-Picture, (2) Two External Composite Video Inputs and (2) Two Composite Video Outputs.

• External DVD and VGA options available on this unit call Aigis for details.

†No Camera Versions add: One External Composite Video Input Except the AFMP Feature Set where it is already included.

4. INSTALLATION

Attention: Installations should be performed by qualified service personnel only in accordance with the National Electrical Code or applicable local codes.



THIS INSTALLATION SHOULD BE MADE BY A QUALIFIED SERVICE PERSON AND CONFORM TO ALL LOCAL CODES.

4.1 Mounting

For specific directions on mounting the see the Instruction Book that came with your mount.

4.2 Power Connections Low Voltage 60Hz PVD

If your unit uses a low voltage power supply, attach the 2 - power leads to your transformer/power supply.

NOTE: To ensure proper AC voltage at the source refer to a copper wire table and line loss table for exact engineering specifications, use the following two charts as a guide.

Maximum distances with specified wire gauges using a 24V 4 amp transformer: 20" PVD	
12 AWG 270 Feet	14 AWG 170 Feet
16 AWG 100 Feet	18 AWG 70 Feet

Maximum distances with specified wire gauges using a 28V 6 amp transformer: 26" PVD	
12 AWG 150 Feet	14 AWG 125 Feet
15 AWG 100 Feet	16 AWG 75 Feet

4.2.1 PVD20-A Units Only If your unit is a PVD20A- version use the following directions to connect the Power and Video.

1. Remove the bottom access panel by removing the four (4) screws shown in **Figure IA**.

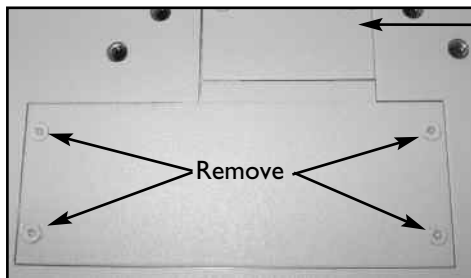

Figure IA : Back view 20" units - Low Voltage Access Panel

Remove this panel only if more space for wires is needed.



Figure IB : Back view 20" units - Low Voltage Access Panel Removed

2. Run the external power wires from the power source, down through the mount and into the back of monitor to the access panel area.
3. Connect one low voltage power lead to each block connector. **Do not connect both wires to one connector.** See **Figure IC**.
4. Make the video connection by connecting the BNC cable as show in **Figure ID**.
5. Tuck the power block into the access panel storage area and secure with the four (4) screws. **Figure ID**.



Figure IC : Back view 20" units - Low Voltage Power Connections

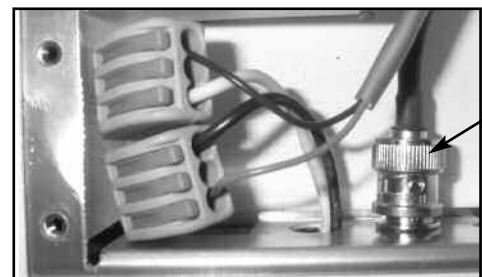

Figure ID : Back view 20" units - Low Voltage Power and Video Connections

Video Connection

4.2.1 PVD20-A Units Only (Continued)

Additional Video Connection and Wire Storage

Note: The block connectors shown in **Figure 1C** can be used to output power allowing the PVD to power an external camera. Be sure that the power supply used has enough wattage to sufficiently power all necessary devices. To utilize this power output, simply connect one low voltage lead to each connector (using remaining free hole) and connect the power cable to a camera or other device. Remove the Exit portion of the Access plate at the perforation as show below to allow the external power wires to exit.

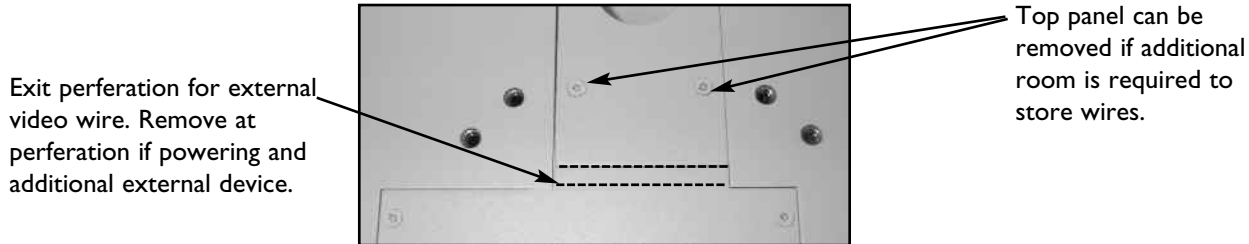

4.3 Power Connections 110VAC

If your unit use a 110VAC/60Hz Power Supply see either **Section 4.3.1** or **4.3.2** depending on the way the power will be directed to the unit.

4.3.1 Power Connection with provided Cord

The CrystalVue™ can be powered with the included Power Cord (A) by plugging directly into the power receiver (B) located on the back. See **Figure 1E**.

Power Cord Protection - Power supply cords should be routed so that they are not likely to be pinched by items placed upon or against them, paying particular attention to cords and plugs and the point where they exit from the appliance.

4.3.2 Using the Right Angle Power Connector

To use your own power leads a Right Angle Power Connector (C) may be used (Not Included) see **Figure 1E**.

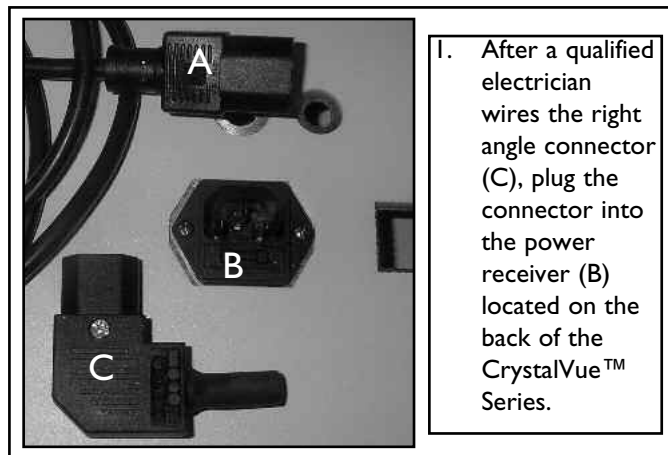

Figure 1E : Back View - 110VAC Power Connections

4.4 Video Connections

1. Connect the external video source to the cable "Video In".
If you wish to run the video back out to a monitoring station, attach the "Video Out" connector to the input of your external monitor.

5. USING THE MENUS

OVERVIEW

On Screen Display Menus

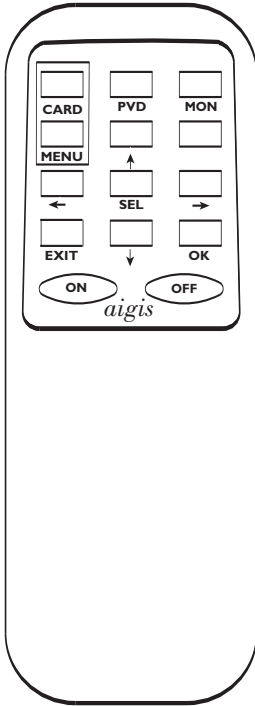

Press PVD to enter and exit the menu.

Press MON to enter and exit the menu.

Press CARD then MENU to enter. Press MENU then CARD to exit

Press SEL to enter and exit the menu.

Menu	Description
PVD MENU	The PVD Menu is used to make adjustments to the factory default settings. Access this menu to change options and settings for both the internal and external video sources, the motion sensor, light sensor, picture in picture (PIP) settings and the switcher. Access the basic internal card reader settings and any advanced setup options under this menu.
MON MENU	The MON Menu allows for minor adjustments to the picture quality of the monitor such as brightness, contrast, color, sharpness and tint.
CARD MENU	The Card Menu controls the internal card reader settings. Adjustments to the slide show format and video with music settings.
SEL MENU	Use this menu to directly access the video input for the Main Video input of the on screen display. Best used to bypass the PVD menu for confirmation of video input selected during setup.

5.1 NAVIGATING THE MENUS

Note: To power the entire unit on or off disconnect at the power source.

To Do This...	Press
Turn On LCD	On
Turn Off the LCD	Off
Display the Main Menus	PVD or MON or SEL
Display the Card Menu	CARD then Menu
Move through the Menus	↑ ↓
Choose Sub Menu	SEL
Move through the Sub Menu options	→
To Do This...	Press
Confirm changes	OK
Save changes in Sub Menu	OK → Yes
Do not save changes in Sub Menu	OK ← No
Exit Sub Menu	EXIT
Exit Main Menus	PVD or MON or SEL
Exit the CARD Menu	MENU then CARD

Menus

5.2 USING THE PVD MAIN MENU

To Access the PVD Menu

Press PVD

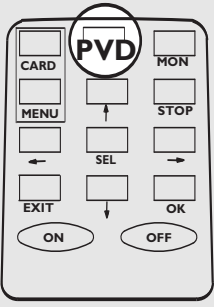

PVD MAIN MENU

MAIN VIDEO SETUP
MOTION SENSOR SETUP
LIGHT SENSOR SETUP
SWITCHER VIDEO SETUP
ADVANCED SETUP

To Do This...	Press
Move through the Menus	↑ ↓
Choose Sub Menu	SEL
Move through the Sub Menu options	→
Save - Sub Menu	OK → Yes
Do Not Save - Sub Menu	OK ← No
Exit Sub Menu	EXIT
Exit Main Menus	PVD

5.3 Using the Main Video Setup Menu

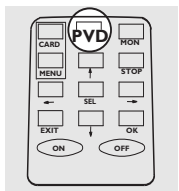

Access the menu by pressing the PVD button.
Press the ↓ to choose Main Video Setup.
Press SEL.

Use this menu to select the Main Video Source and PIP (Picture in Picture) settings.

MAIN VIDEO SETUP

VIDEO SOURCE
PIP VIDEO SOURCE
PIP SIZE
PIP LOCATION

Main Video Setup - Menu Options

• - Option Included X - Option Not Included

Feature	Option	Description	Feature Sets*				
			N ¹	MP ²	FMP ³	AFMP ⁴	No Camera ⁵
Video Source <i>Selects the Main Video source.</i>	Int Cam	Internal built in Camera	•	•	•	•	X
	Ext Video 1	External Video Source 1	X	•	•	•	•
	Ext Video 2	External Video Source 2	X	X	X	•	X
	Int Card	Internal Card Reader Video	X	X	•	•	X
PIP Video Source <i>Selects PIP video source the Main Video.</i>	Int Cam	Internal built in Camera	X	•	•	•	X
	Ext Video 1	External Video Source 1	X	•	•	•	X
	Ext Video 2	External Video Source 2	X	X	X	•	X
	Int Card	Internal Card Reader Video	X	X	•	•	X
PIP Size <i>Selects the size of all PIP windows.</i>	Small	Small PIP window	X	•	•	•	X
	Large	Large PIP window	X	•	•	•	X
	Split	Split Screen proportionately	X	•	•	•	X
	Split/Full	Split Screen stretches and fills the screen	X	•	•	•	X
PIP Location <i>Selects the on screen location for all PIP windows.</i>	Top L	Internal built in Camera	X	•	•	•	X
	Top R	External Video Source 1	X	•	•	•	X
	Bottom R	External Video Source 2	X	•	•	•	X
	Bottom L	Internal Card Reader Video	X	•	•	•	X

Note: Video Source and PIP Video Source cannot be set to the same input source.

Feature Sets*

1 - (N) Security 2 - (MP) Security/Marketing 3 - (FMP) Security / On Board Marketing
4 - (AFMP) Full Featured 5 - No Camera

5.4 Using the Motion Sensor Setup Menu

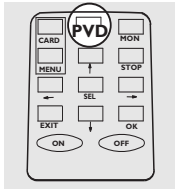

Access the menu by pressing the **PVD** button.
Press the ↓ to choose **Motion Sensor Setup**.
Press **SEL**.

Use this menu to activate and setup the video, PIP, sensitivity and dwell time for the Motion Sensor.

MOTION SENSOR SETUP
VIDEO SOURCE
PIP VIDEO SOURCE
SENSITIVITY
DWELL TIME
SENSOR ON/OFF

Motion Sensor Setup - Menu Options

• - Option Included X - Option Not Included

Feature	Option	Description	Feature Sets				
			N ¹	MP ²	FMP ³	AFMP ⁴	No Camera ⁵
Video Source <i>Selects the video source for Motion Sensor</i>	Int Cam	Internal built in Camera	X	•	•	•	X
	Ext Video 1	External Video Source 1	X	•	•	•	X
	Ext Video 2	External Video Source 2	X	X	X	•	X
	Int Card	Internal Card Reader Video	X	X	•	•	X
PIP Video Source <i>Selects PIP video source for the Motion Sensor.</i>	Int Cam	Internal built in Camera	X	•	•	•	X
	Ext Video 1	External Video Source 1	X	•	•	•	X
	Ext Video 2	External Video Source 2	X	X	X	•	X
	Int Card	Internal Card Reader Video	X	X	•	•	X
	No PIP	No PIP will display	X	•	•	•	X
Sensitivity <i>Sets how sensitive the Motion Sensor is to Motion.</i>	1-10	1 = not sensitive 10 = most sensitive	X	•	•	•	X
Dwell Time <i>Selects the length of time the Motion Sensor settings will remain on screen.</i>	5-59	Choose in seconds the length of time the Motion Sensor Settings will play after motion is detected before switching back to Main Video settings.	X	•	•	•	X
Sensor on/off <i>Activate or Deactivate the motion sensor.</i>	On	Activates Motion Sensor	X	•	•	•	X
	Off	Deactivates Motion Sensor	X	•	•	•	X

Note: Video Source and PIP Video Source cannot be set to the same input source.

Note: After motion is detected by the Motion Sensor the on screen video will switch to the Motion Sensor settings set in this menu and stay on screen for between 5-59 seconds.

Menus

Feature Sets*

1 - (N) Security 2 - (MP) Security/Marketing 3 - (FMP) Security /On Board Marketing
4 - (AFMP) Full Featured 5 - No Camera

5.5 Using the Light Sensor Setup Menu

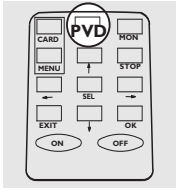

Access the menu by pressing the PVD button.
Press the ↓ to choose Light Sensor Setup.
Press SEL.

LIGHT SENSOR SETUP
VIDEO SOURCE
PIP VIDEO SOURCE
SENSITIVITY
ACTIVATION DELAY
SENSOR ON/OFF
(Flip/Mirror**)

Use this menu to setup the video, PIP, sensitivity and activation delay for the Light Sensor. In some units the Flip/Mirror settings appear in this menu, use the Flip/Mirror to rotate or reflect the on screen image.

• - Option Included X - Option Not Included

Light Sensor Setup - Menu Options

Feature	Option	Description	Feature Sets*				
			N ¹	MP ²	FMP ³	AFMP ⁴	No Camera ⁵
Video Source Selects the Light Sensor video source.	Power Save	Turns the LCD backlight off	X	•	•	•	X
	Int Cam	Internal built in Camera	X	•	•	•	X
	Ext Video 1	External Video Source 1	X	•	•	•	X
	Ext Video 2	External Video Source 2	X	X	X	•	X
	Int Card	Internal Card Reader Video	X	X	•	•	X
PIP Video Source Selects the PIP video source for the Light Sensor.	Int Cam	Internal built in Camera	X	•	•	•	X
	Ext Video 1	External Video Source 1	X	•	•	•	X
	Ext Video 2	External Video Source 2	X	X	X	•	X
	Int Card	Internal Card Reader Video	X	X	•	•	X
	No PIP	No PIP will display	X	•	•	•	X
Sensitivity Sets how sensitive the Light Sensor is to a change in ambient light.	1-10	1 = not sensitive 10 = most sensitive	•	•	•	•	•
Activation Delay The amount of time set to delay activation of the Light Sensor settings.	1-3 min	Choose 1, 2 or 3 minutes	•	•	•	•	•
	Off	No Delay	•	•	•	•	•
Sensor On/Off Activate or Deactivate the Light Sensor.	On	Activates Light Sensor	•	•	•	•	•
	Off	Deactivates Light Sensor	•	•	•	•	•
Flip/Mirror** Rotates and/or mirrors the video on screen.	Normal	Right Side up / Not Mirrored	•	•	•	•	•
	Mirror	Right Side Up / Mirrored Image	•	•	•	•	•
	UpSide Down	Rotates Image 180°	•	•	•	•	•
	Up Mir	Mirrors Image and Rotates 180°	•	•	•	•	•

Note: Video Source and PIP Video Source cannot be set to the same input source.

Note: After a change in ambient light is detected the video will switch to the Light Sensor settings chosen in this menu.

These settings will stay active until an increase in ambient light occurs to reactivate the Main Video settings.

Note: After a change in ambient light is detected the Light Sensor settings can be set to delay activation between 1-3 minutes.

** Flip/Mirror Options are located in this menu in feature sets:
(N) Security and No Camera
All Other Feature sets see the Advanced Setup Menu for Flip/Mirror.

Feature Sets*

1 - (N) Security 2 - (MP) Security/Marketing 3 - (FMP) Security / On Board Marketing
4 - (AFMP) Full Featured 5 - No Camera

5.6 Using the Switcher Video Setup Menu

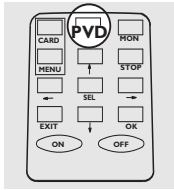

Access the menu by pressing the PVD button.
Press the ↓ to choose Switcher Video Setup.
Press SEL.

Use this menu to setup PVD units with multiple video inputs. Set an additional video source and PIP to activate upon a preset dwell rate and set the dwell rate for the Main Video settings once the Run Switcher is set to ON.

SWITCHER VIDEO SETUP
VIDEO SOURCE
PIP VIDEO SOURCE
RUN SWITCHER
SWITCHER DWELL
MAIN VIDEO DWELL

• - Option Included X - Option Not Included

Switcher Video Setup - Menu Options

Feature	Option	Description	Feature Sets*				
			N ¹	MP ²	FMP ³	AFMP ⁴	No Camera ⁵
Video Source <i>Selects the video source for the Switcher.</i>	Int Cam	Internal built in Camera	X	•	•	•	X
	Ext Video 1	External Video Source 1	X	•	•	•	X
	Ext Video 2	External Video Source 2	X	X	X	•	X
	Int Card	Internal Card Reader Video	X	X	•	•	X
PIP Video Source <i>Selects the PIP video source for the Switcher.</i>	Int Cam	Internal built in Camera	X	•	•	•	X
	Ext Video 1	External Video Source 1	X	•	•	•	X
	Ext Video 2	External Video Source 2	X	X	X	•	X
	Int Card	Internal Card Reader Video	X	X	•	•	X
	No PIP	No PIP will display	X	•	•	•	X
Run Switcher <i>Activates the Switcher Video Settings.</i>	On	Activates the Switcher Settings	X	•	•	•	X
	Off	Deactivates the Switcher Settings	X	•	•	•	X
Switcher Dwell <i>Length of time the Switcher Video Settings will display on screen.</i>	5-59	Choose in seconds, the length of time in that the Switcher Video Settings will display on screen before switching to the Main Video Settings.	X	•	•	•	X
Main Video Dwell <i>Length of time the Main Video Settings will display on screen.</i>	5-59	Choose in seconds, the length of time in that the Main Video Settings will display on screen before switching to the Switcher Video Settings.	X	•	•	•	X

Note: Video Source and PIP Video Source cannot be set to the same input source.

Note: Run Switcher must be set to On to activate the settings in this menu.

Note: Once the Run Switcher is set to ON the Main Dwell can be set.

Feature Sets*

1 - (N) Security 2 - (MP) Security/Marketing 3 - (FMP) Security /On Board Marketing
 4 - (AFMP) Full Featured 5 - No Camera

5.7 Using the Advanced Setup Menu

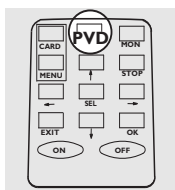

Access the menu by pressing the PVD button.
Press the ↓ to choose Advanced Setup.
Press SEL.

Use this menu to:
Reset the all menu settings to original Factory Defaults.
Rotate or reflect the on screen image.
Set the type of video to play through the Internal Card reader.
Choose the source of the audio input.

ADVANCED SETUP
FACTORY DEFAULT
FLIP/MIRROR
INT CARD SETUP
AUDIO SOURCE

Advanced Setup - Menu Options

• - Option Included X - Option Not Included

Feature	Option	Description	Feature Sets*				
			N ¹	MP ²	FMP ³	AFMP ⁴	No Camera ⁵
Factory Defaults	On	Reset to Factory Defaults.	X	•	•	•	X
	Off	Set to On, the PVD will reset all settings and options and return to the OFF position allowing new changes.	X	•	•	•	X
Flip/Mirror <i>Rotates and/or mirrors the video on screen.</i>	Normal	Right Side up / Not Mirrored	•	•	•	•	•
	Mirror	Right Side Up / Mirrored Image	•	•	•	•	•
	UpSide Down	Rotates Image 180°	•	•	•	•	•
	Up Mir	Mirrors Image and Rotates 180°	•	•	•	•	•
Int Card Setup <i>Selects type of images from the Internal Card Reader.</i>	None	No Video or Slide show will play	X	X	•	•	X
	Slide Show	Still images will play from the internal card reader.	X	X	•	•	X
	Video	Motion Video will play from the internal card reader.	X	X	•	•	X
Audio Source <i>Selects Internal Audio or External Audio source.</i>	None	No Audio will play.	X	X	X	•	X
	Internal	Chooses Internal Audio Source	X	X	X	•	X
	Video	Chooses External Audio Source	X	X	X	•	X

Feature Sets*

1 - (N) Security 2 - (MP) Security/Marketing 3 - (FMP) Security /On Board Marketing
4 - (AFMP) Full Featured 5 - No Camera

5.8 Using the MON Menu

Note: It is recommended that NO changes be made to the MON Set Up Menu as they may conflict with the PVD's preconfigured circuit board programming.

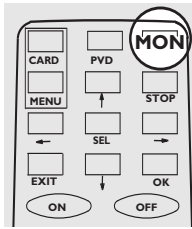

Access the menu by pressing the **MON** button.
 Press the **↓** to choose, press **→** choose option.
 Press **MON** to exit.

The MON Menu allows for minor adjustments to the picture quality of the monitor such as brightness, contrast, color, sharpness and tint.



MON MENU SELECTIONS

PICTURE
PIP/POP/PBP
SET UP

“MON” Menu Settings Overview

MON MENU	SUB MENU	2nd SUB-MENU	CONTROL
PICTURE	BackLight	Factory Set 75%	0 - 100
	PSM (Pre-Set Mointor Settings by type)	Factory Set Standard - Dynamic/Standard/Mild/Game/User	
		USER	Brightness Contrast Color Sharpness
	CSM (Color Warmth Settings for the Video on Screen)	Factory Set Normal Cool Worm1 Worm2	
User		Red/Green/Blue	
PIP/POP/PBP	NOT AVAILABLE WITH THIS UNIT	No settings will save.	
SETUP	Language	English/Deutsch/FranAois/Italiano/Espanol/Korean	
	Transparency	0 (0 ~ 100)	
	ISM Method	Factory Set Normal - DO NO CHANGE Normal, Orbit, White	
	Set ID On/Off	MUST BE SET TO (ON) -- DO NOT CHANGE	
	Set ID	MUST BE SET TO (1) -- DO NOT CHANGE	
	Flip	DO NOT CHANGE -- USE PVD MENU FOR THIS OPTION	
	Factory Reset	Defaults to Factory Settings	
Sound Source	N/A		

MON Settings - Sub-Menu PICTURE

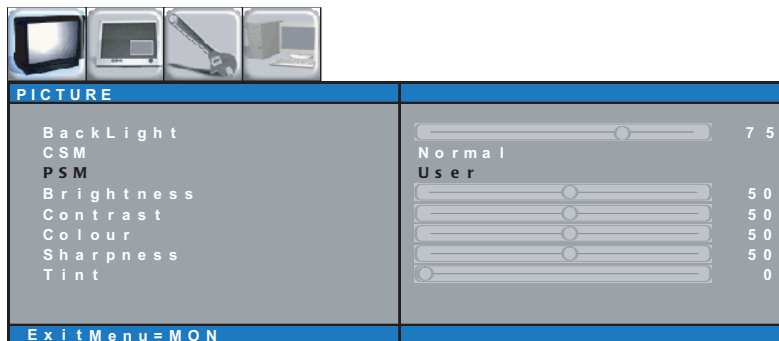
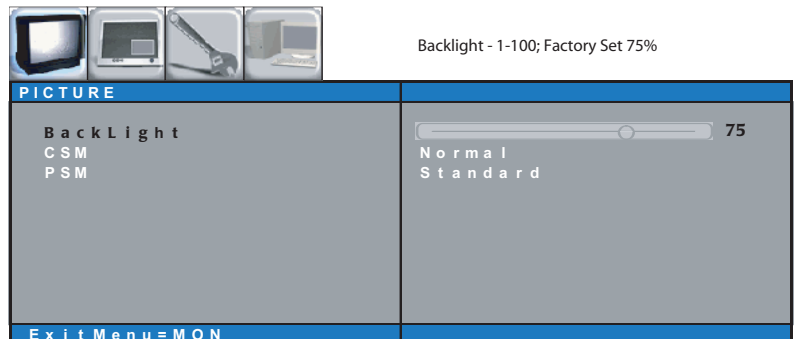

Backlight - 1-100; Factory Set 75%

CSM - Color Warmth Settings : Factory Set to Normal Cool / Warm1 / Warm2

PSM - Pre-Set Monitor Settings By Type:

Factory Set to : Standard

Mild

Game

User: Customized by End User has its own sub menu Dynamic

PSM - Pre-Set Monitor Settings By Type:
 User Menu Adjust: / Brightness / Contrast/
 Color / Sharpness / Tint

5.8.1 Monitor Control Buttons

Note: It is recommended that Monitor Settings should be adjusted by using the Remote Control On Screen Display Menus, see **5.8 Using the MON Menu, Not by using the Monitor Control Buttons.**

Adjustments to the Monitor Settings may be made by navigating through the menus and sub-menus with the CrystalVue buttons™. See section **5.8 Using the MON Menu** for menu details.

Use the On/Off button to Reset the unit.



Button	Function	Status	HOTKey
LED	Indicates operation status	Green/ Off/ Amber	
Power	Power on/off	On/Off	
Menu	Activate menu		
Select	Menu Select		No OSD, Auto Adjust
LEFT	Cursor control Left	First Activate Menu Key	Volume Down
RIGHT	Cursor control Right	First Activate Menu Key	Volume Up
DOWN	Cursor control Down	First Activate Menu Key	
UP	Cursor control Up	First Activate Menu Key	
Source	Source change		

Figure 2: Internal Monitor Control Buttons

Power On and Off Button. Use this button to power on the unit for use.

Menu: Use this button to call up the On Screen Display (OSD) menus on the monitor and to exit the (OSD).

Select item from menu and to save changes after making adjustments.

Scroll **Down** the menu

Scroll **Up** the menu

Scroll **Left** on the menu

Scroll **Right** on the menu

Power LED Display Light:

Green Light indicates Video On

Amber Light indicates Video Loss

6. FLASH MEMORY AND MOTION DETECTION

6.1 Activate the Internal Card reader Video

1. If the unit is supplied with an Internal Card Reader insert a SD memory card with a base line JPG image in its root directory to activate the image on the card press play on the Remote Control. The unit will automatically display the JPG image.
2. If more than one JPG is on the card, the PVD will display a slide show rotating through all supplied JPG images.

6.2 Adjust the Motion Sensor Orientation

1. To make any needed adjustments to the Motion Sensor (PIR) access the back panel of the PVD by unscrewing the two thumb screws.
2. The motion sensor is located to the far left side of the panel as you are facing the back of the PVD. See Figure 3.

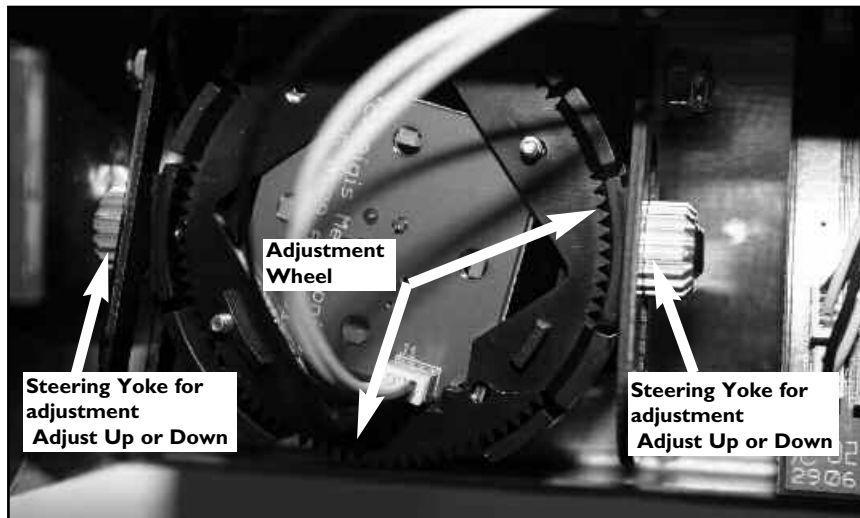
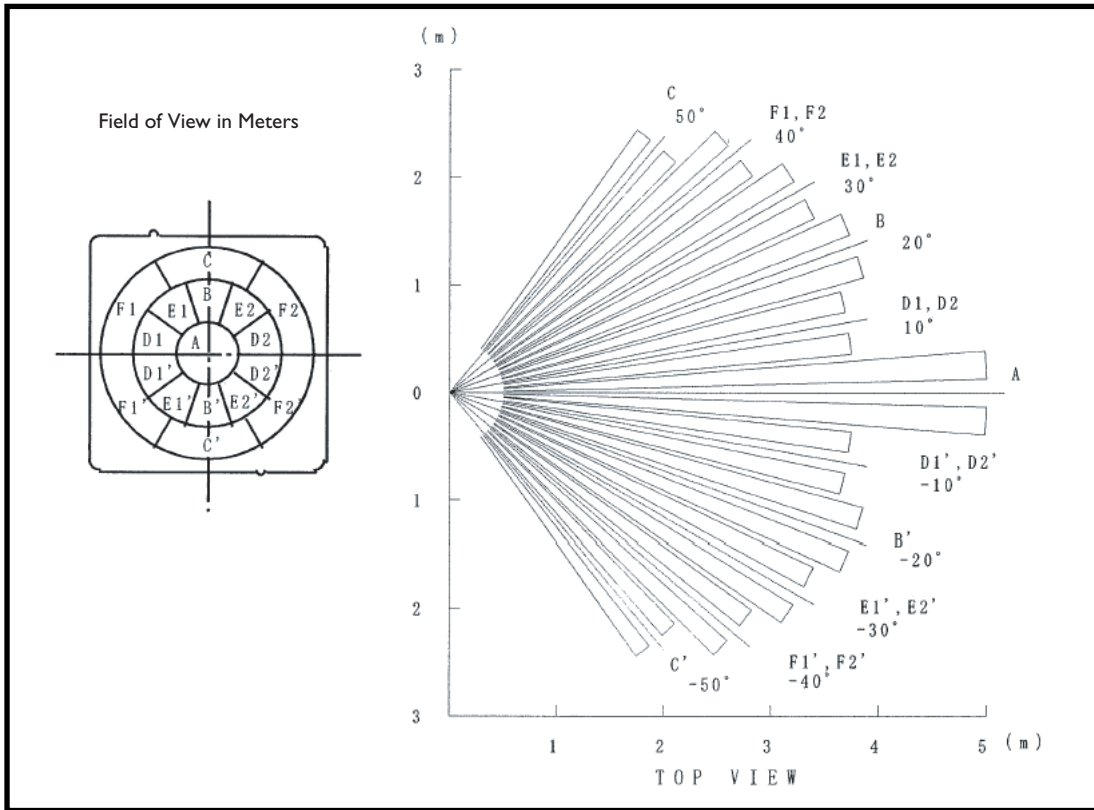

Figure 3: Motion Sensor

3. Adjustments can be made to the Sensor by rotating the adjustment wheel in either direction by moving it clockwise or counter clockwise. The sensor can also be moved in an up and down orientation by unscrewing slightly the steering yoke and sliding the sensor up or down then retightening.
4. The standard PIR detects motion by sensing left to right or right to left in a horizontal fashion. To change the orientation of the sensor simply begin adjustments as explained in step 3 until the sensor begins to detect in the field of view desirable.
5. The following chart may be helpful when determining the pattern of movement most desirable for the area the PVD is installed in.

6.2.1 Motion Sensor Field of View in Meters

Top View



Side View

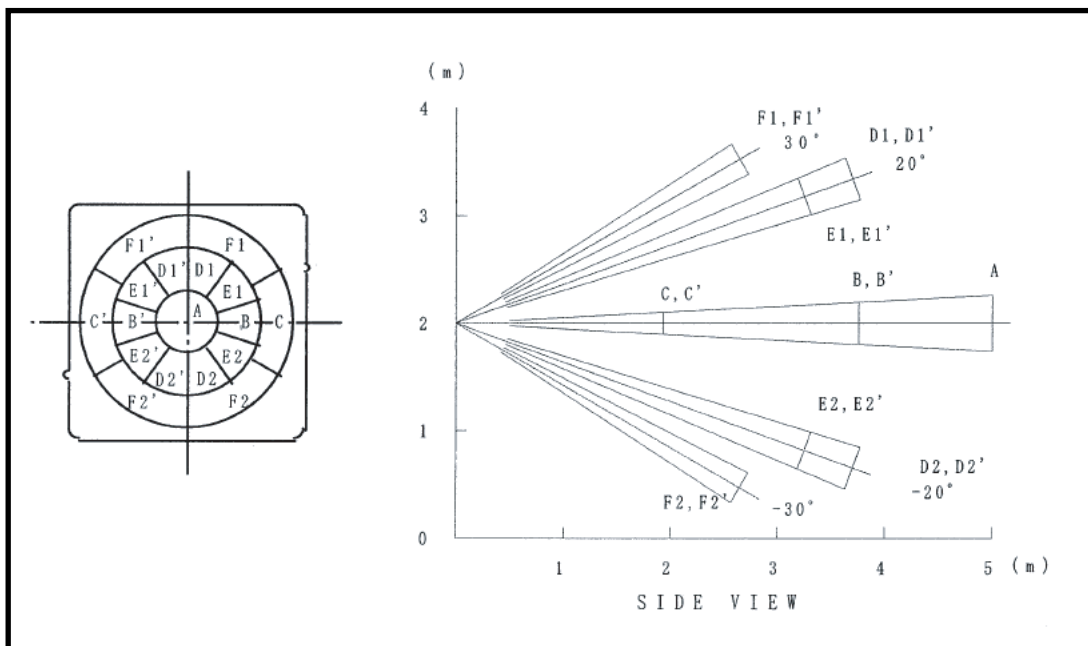

7. INTERNAL CONTROL BOARD

7.1 Control Board Configurations and Option Switches

The Control Board is a microprocessor-based circuit that controls the on-board sensors and the video switcher. The main purpose of this switcher is to select the Main Video settings to be displayed on screen and then switch the video to either Light Sensor, Motion Sensor or Switcher Video settings. It may also be directed to ignore the sensors and select one or both of the Main Video or Switcher Video settings at settable dwell rates.

Verify the operations of the Control Board

1. Located on the control board are the Control Board LED's. See **Figure 4**.
2. Verify that the "Power LED" is Green signifying the PVD is on.
3. The "System Pulse LED" will be dull red showing the control board is running.
4. The "Camera On LED" is lit when the motion detection is selected and off when the auxiliary input is selected.

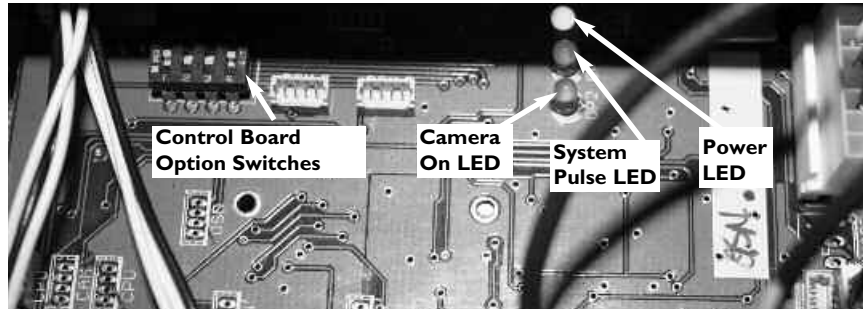

Figure 4: Control Board

7.2 Detail of Option Switches

Options may be controlled via the four "Options Switches," see **Figure 4**, see **Detail A** for their respective functions. It is advised to verify operation first by using the On Screen PVD Menu to control these options. After verification of settings via the PVD Menu the Control Board Option switches can be accessed.

Detail A

Note: is factory setup

1	Motion Switcher	ON	Enable Motion Switcher
		OFF	Disable Motion Switcher
2	Ambient Light Control	ON	Control of Aux Video Amp
		OFF	No Control of Aux Video Amp
3	Synchronization Mode	ON	Sync to Aux Video
		OFF	Sync to Line
4	Light Sensor	ON	Enable Light Sensor
		OFF	Disable Light Sensor

8 Camera Adjustments

8.1 Camera Adjustments

Refer to the following sections to setup the camera for operation. The camera module position can be adjusted both vertically and horizontally and can also be rotated for proper tilt orientation.

See **Figures 5** or **6** for the correct camera series adjustment points.

8.1.1 Color High Resolution Series Camera

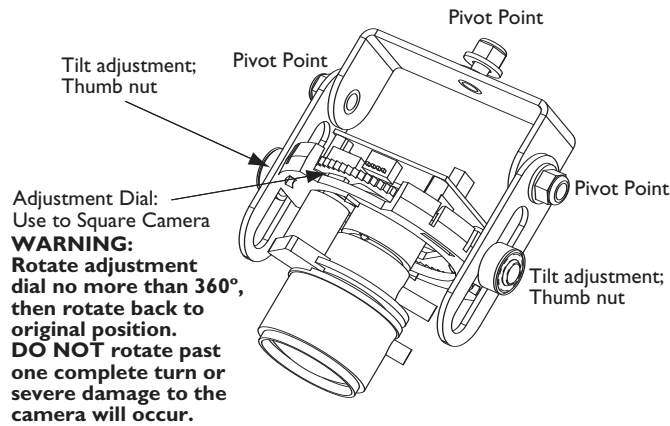

Figure 5: Color High Resolution Camera Adjustment Points

8.1.2 Wide Dynamic Range (WDR) Series Camera

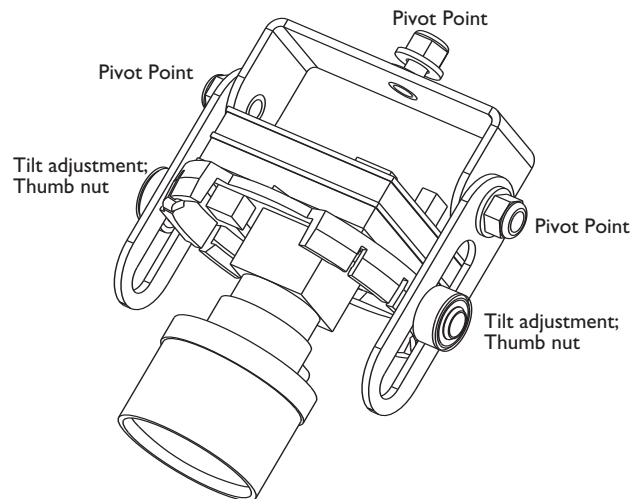

Figure 6: Wide Dynamic Range (WDR) Camera Adjustment Points

8.2 Camera and Lens Settings

The camera module has various settings for any additional adjustments that may be required. See **Figure 7 or 8** for the correct camera series settings and dip switch locations.

8.2.1 Dip Switch Location for Color High Resolution Camera

See **Detail B** for dip switch information.

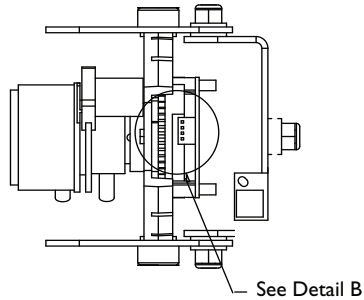

Figure 7: Dip Switch Location: Color High Resolution Camera

DETAIL B
The following chart diagrams the selectable dip switches and their respective functions for the Color High Resolution Camera:

IRIS	FL	BLC	Sync
DC	ON	ON	INT
1	2	3	4

Note: is factory setup

1	IRIS	DC	DC IRIS
		AES	AES
2	Flickerless (FL)	ON	Shutter speed to be fixed at 1/100 sec.
		OFF	Normal position
3	Backlight Compensation (BLC)	ON	Set to this position when a strong light is in the back ground.
		OFF	Normal position
4	Synchronization Mode	INT	Internal Synchronization mode
		L.L.	Line lock mode

8.2.2 Dip Switch Location for Wide Dynamic Range (WDR) Camera

See **Detail C** for dip switch information.

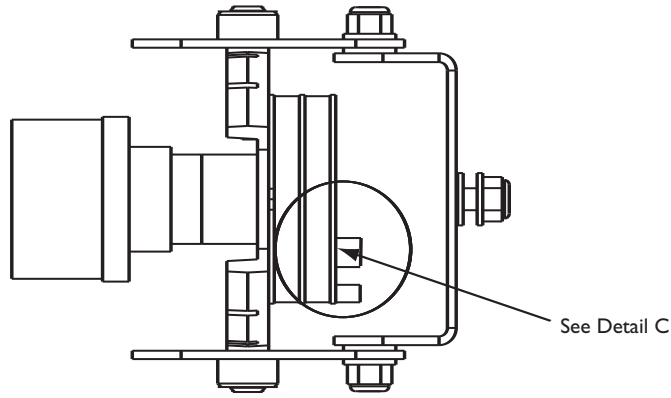

**Figure 8: Dip Switch Location:
Wide Dynamic Range (WDR) Camera**

DETAIL C

The following diagram shows the selectable dip switches for the Wide Dynamic Range (WDR) Camera:

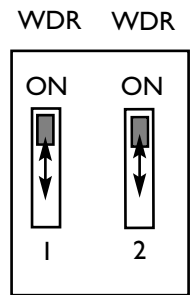

Note:  is factory setup

8.3 Focusing the Camera

Adjust the focus on the camera by adjusting the rings around the lens until the picture is sharp and clear. Adjust the camera to the proper tilt position, see **Figures 5** or **6** for your camera series.

SPECIFICATIONS

CrystalVue™ PVD

	CrystalVue™ Size 20.1"	CrystalVue™ Size 26"	CrystalVue™ Size 32"	CrystalVue™ Size 37"
Resolution	640H x 480V Pixels RGB WXGA		1366H x 768V Pixels RGB WXGA	
Pixel Pitch	0.637mm x 0.637mm	0.1405mm x 0.4215	0.170mm x 0.510mm	0.200mm x 0.600MM
Luminance White/Brightness	550 cd/m ² (Center 1 Points Typ.)	600 cd/m ² (Center 1 Points Typ.)	600 cd/m ² (Center 1 Points Typ.)	600 cd/m ² (Center 1 Points Typ.)
Contrast Ratio	800 : 1 Typ.	1400: 1 Typ.	1600 : 1 Typ.	
Aspect Ratio	4:3	16:9		
Viewing Angle	178/178° U/D/L/R			
Number of Colors	16.7M(8bit)			
Lamp Life	Over 50,000 Hrs			
Response Time	25ms	8ms (GTG)		
Light Sensor	Dwell, Sensitivity – Programmable action upon light reduction			
14 Button Remote Control	Access OSD On for Monitor Setup; Video Input Selection – feature set -up			
On Screen Display (OSD)	Light Sensor, Motion, Audio, Video, Picture-in-Picture			
Power Requirement	24 VAC +/- 10% 80W	120 VAC (Optional 24VAC +/- 10% 125W)	120 VAC (Optional 24VAC +/- 10% 150W)	120 VAC (Optional 24VAC +/- 10% 175W)
Color	Standard Colors - White (W) or Black (B) Custom colors are available - Call factory for details			
Options				
Motion Detection	Programmable Built-in PIR Motion detector, PIR Controls Video, 0-60 Sec Dwell			
Flash Card Reader	Content Format Support: MP3s, WMA, JPEG, MJPEG (.AVI, 320x240 Pixels, 15f/sec), MPEG-I (VCD, SVCD, .dat), MPEG (720x480 pixels), MPEG (.asf, simple profile), JPEG Slideshow with MP3 background music, DIVX 5 Compatible Flash Cards: SmartMedia™ card, Secure Digital™ card, CompactFlash™ type I/II, IBM Microdrive™, MultiMedia™ card, Memory Stick™, Memory Stick Pro™ card			
Audio	2 Watts per channel (2 channels)			
Picture-in-Picture Split Screen	Adjustable Picture Box Size and Location			
Full Featured Option Only	DVI Input or VGA Input			

Camera Specifications

	Color	Wide Dynamic Range
Horizontal Resolution	480TVL	
Sensitivity - Min. Scene Ill. f/1.2 lens	1.2 lux (50 IRE)	0.5 lux (30 IRE)
Imager	1/4-inch Image Format; Interline Transfer CCD	1/3-inch Image Format; Interline Transfer CCD
System	NTSC	
Signal to Noise	48dB	50dB
Electronic Shutter	1/60 EIA to 1/100,000	
Backlight Compensation	Selectable On/Off Control	Yes
White Balance	Automatic Sensing through the Lens (TTL System): +2700 K to 9000 K.	
Video Output	Composite; 1.0 Vp-p, 75ohm	
Phase Adjust	0° to 330°	
Controls	Line lock on/off; AWB on/off; AGC on/off; Gamma on/off; BLC on/off	WDR on/off;

Lens Specifications

	Focal Range	Iris Range	Iris/Shutter	Format
Color -36	3-6mm	f/1.2 - 360	DC Auto Iris	1/4-inch
WDR -39	3.8-9.5mm	f/1.3 - 360	DC Auto Iris	1/3-inch

Optional Lens -24 2-4mm
 Optional Lens -210 2.8-10mm
 Call Aigis for Details

SPECIFICATIONS

Environmental

	Rated for Indoor Use Only	
Temperature	Operating	0°C to +50 °C (32°F to 122°F)
	Storage	-20°C to +60°C (-4°F to 140°F)
Humidity	10-90 %RH Non-Condensing	

Mechanical Specifications

	Construction	Aluminum with Acrylic front window			
Housing	Finish	Standard: Powder coated black or white finishes. Custom finishes available.			
	Weight	20" 15 lbs.	26" 25lbs.	32" 40lbs	37" 45lbs.

SPECIFICATIONS ACCESSORIES

Power Supplys

	Use the corresponding part numbers to order the Power Supply for the appropriate size CrystalVue™
PS-24VA4A-PB	PVD20 - Power Supply that converts 120VAC to 24VAC, 4Amp output, includes 6 ft. Power Cord and Box
PS-24VA6A-PB	PVD26, PVD32, PVD37 - Power Supply that converts 120VAC to 28VAC, 6Amp output, includes 6 ft. Power Cord and Box

Mounting Kits

	CrystalVue's™ mounting kits install with a unique feed-thru ball mount system that allows complete adjustability for optimal viewing and no visible wires. Choose from the Ceiling, Truss or Wall Kits made exclusively for the CrystalVue™. Kits are available in Black or White finish with custom colors available upon request.
PVD-MK-CEILING	Ceiling Kit - Includes one metal ceiling tile for a standard 2' x 2' drop ceiling grid, two 4' adjustable threaded poles with safety locking ring and coupler, four safety wires, and one feed-thru pole mount made from aluminum painted to match.
PVD-MK-TRUSS	Truss Mount Kit - Includes a truss mount with center coupler and set screw, two 4' adjustable threaded poles with safety locking ring and coupler and one feed-thru pole mount made from aluminum painted to match.
MTFPF12F-	WALL MOUNT KIT - Includes a 12" feed-thru wall mount with flange coupling and one aluminum feed-thru adjustable ball joint, all painted to match.

DIMENSIONAL OUTLINES

CrystalVue™ 20"

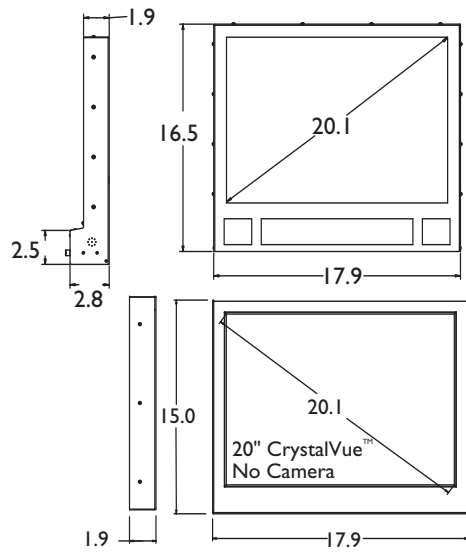

CrystalVue™ 26"

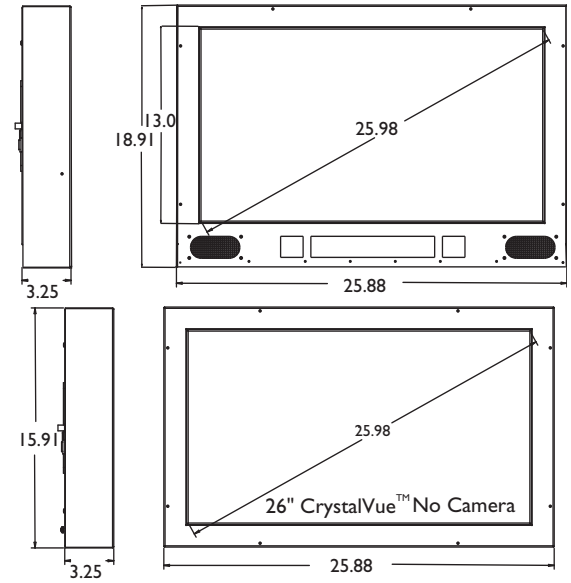

CrystalVue™ 32"

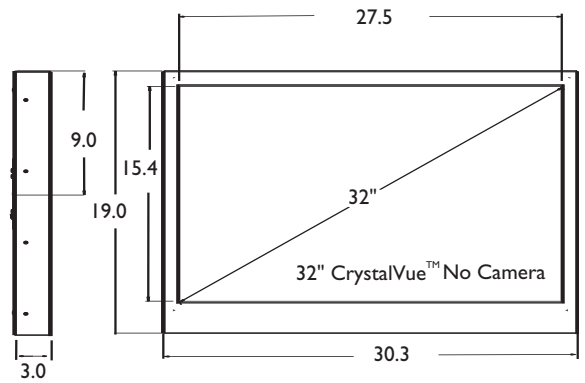
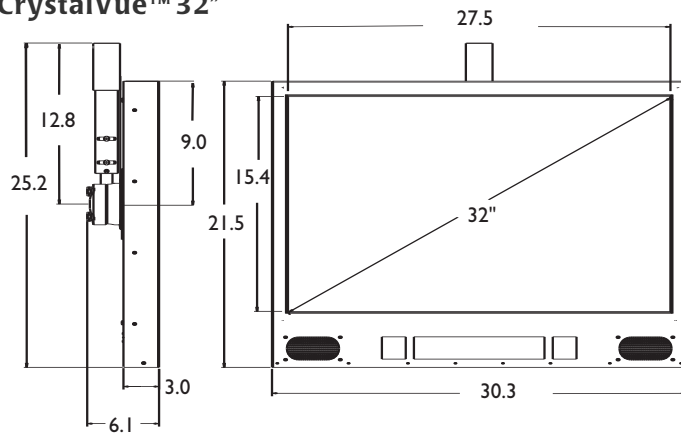

CrystalVue™ 37"

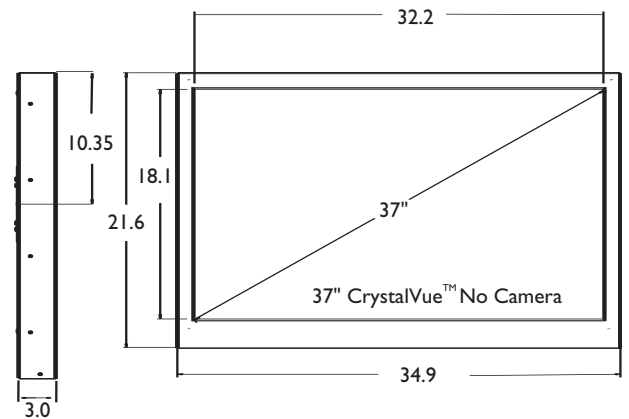
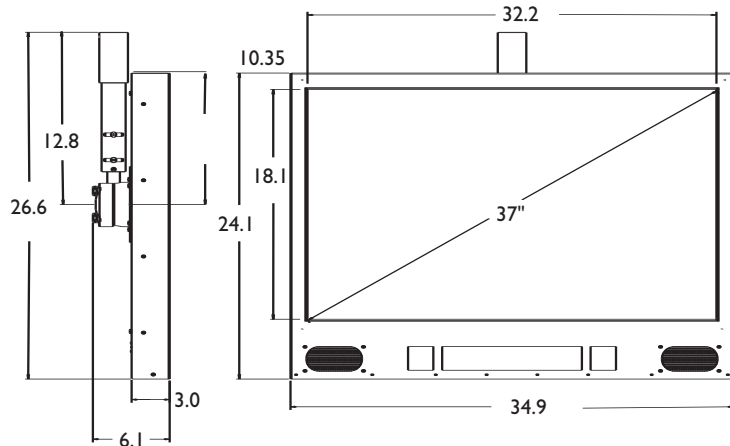



©2005 Aigis Mechtronics
1124 Louise Road Winston-Salem, NC 27107-5450
Tel: 336.785.7740 Fax: 336.785.7744
Data subject to change without notice.

AIG 03/07
Draft Printed in U.S.A.