

# Custom and Configure Services

Linear Customized Security Design and Manufacturing Solutions

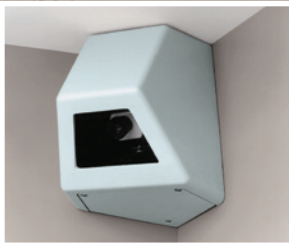

Mechanical Security Products

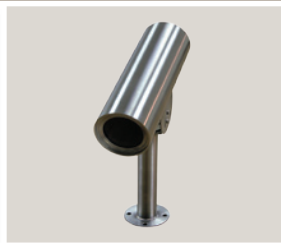
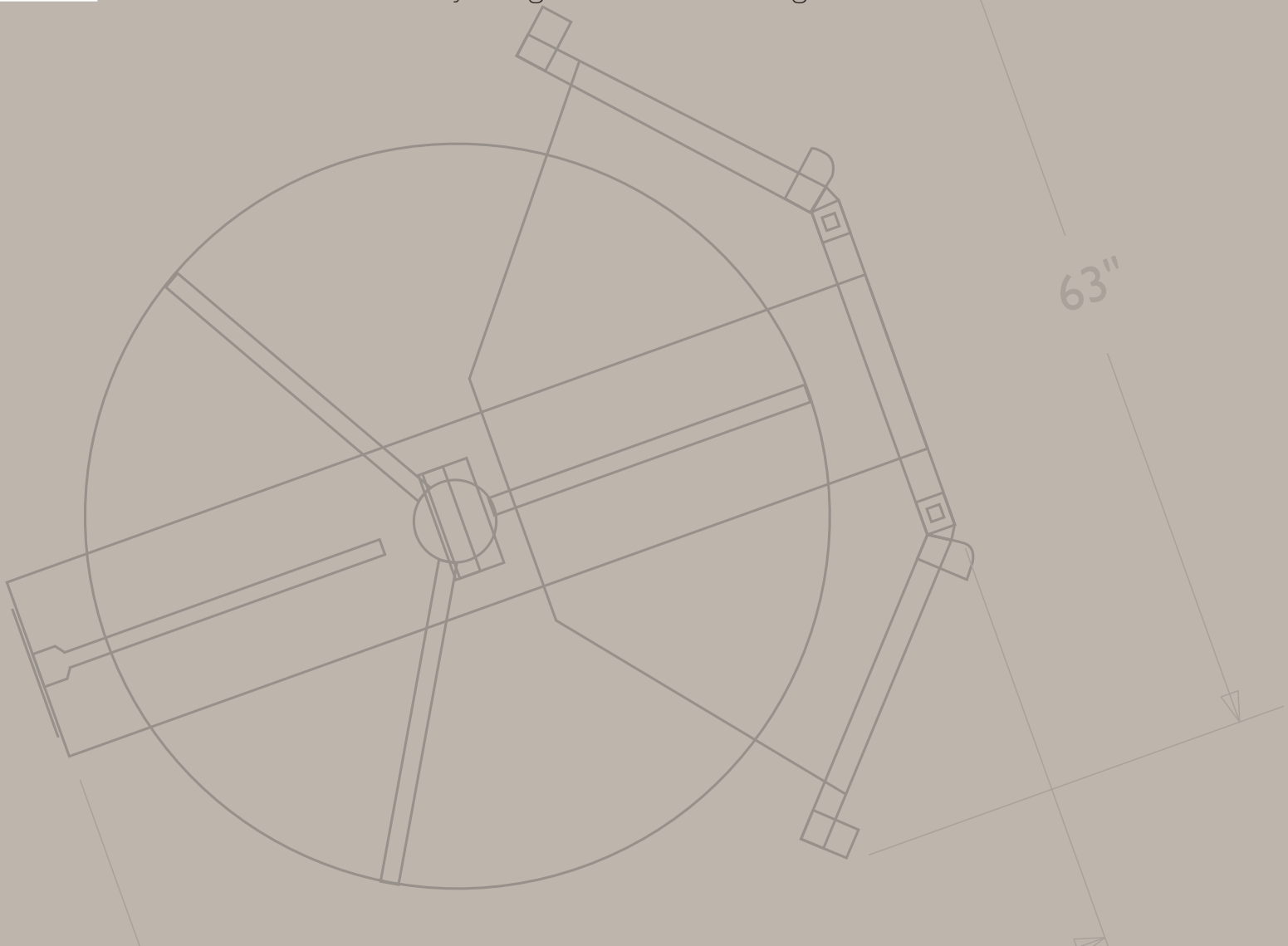

**Your unique challenge is our specialty...**

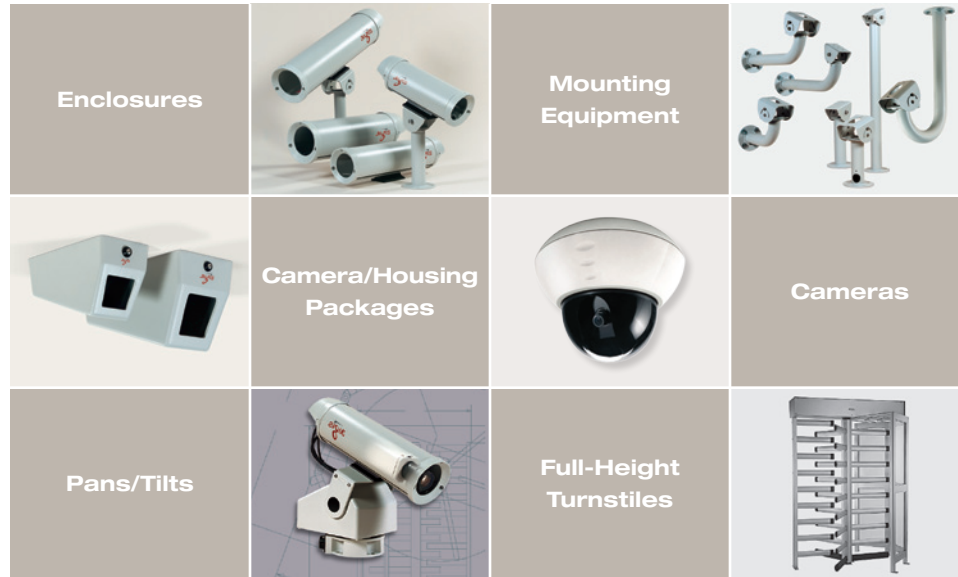

**Linear’s Aigis line leads the industry in customized mechanical surveillance**

From standard housings to mounting equipment, Linear’s Aigis product line provides a diverse range of equipment that serves to protect, position and mount CCTV surveillance equipment.

But your options don’t stop there ...

Wide varieties of applications require unique solutions. Linear recognizes this and will work with you to design any product to accurately meet your mechanical needs.

Reasons to choose Aigis’ customized solutions ...

- **Unique Size Requirements**
- **Non-Standard Mounting Surfaces**
- **Blend with Existing Decor**
- **Harsh or Extreme Environmental Needs**
- **Match Architectural Styles**

**Case Study:** Washington D.C.

**Challenge:** Limited options to expand CCTV camera presence while respecting existing architectural design aesthetics.

**Solution:** A customized camera package that matches existing design, finish and architectural details.



## Why spend time installing cameras into housings when Linear can do it for you?

Linear will factory-configure any of its Aigis brand housings with a camera and lens of your choice. Every package can be completely pre-wired and backfocused making it truly plug and play.

### Custom Configuration Services

Specify a camera and lens from Linear's Aigis line - or supply your own - and Linear will work with you to configure a finished product that meets your needs.

A variety of smaller, compact packages with integrated board camera/lens combinations are also available. Choose from the options shown online, or contact Linear with your specific requirements.

### Popular Custom Services

- Custom Finishing/Painting
- Specialized Mounting Applications (extend, shorten, customized to surface or mounting location)
- Environmental Protection/Extended Temperature Range
- Component Integration
- System Configuration
- Design Engineering



- Ensure optimal performance when set up and tested factory

- Save on installation time and cost

- Reduce mistakes when specifying camera and lens combinations

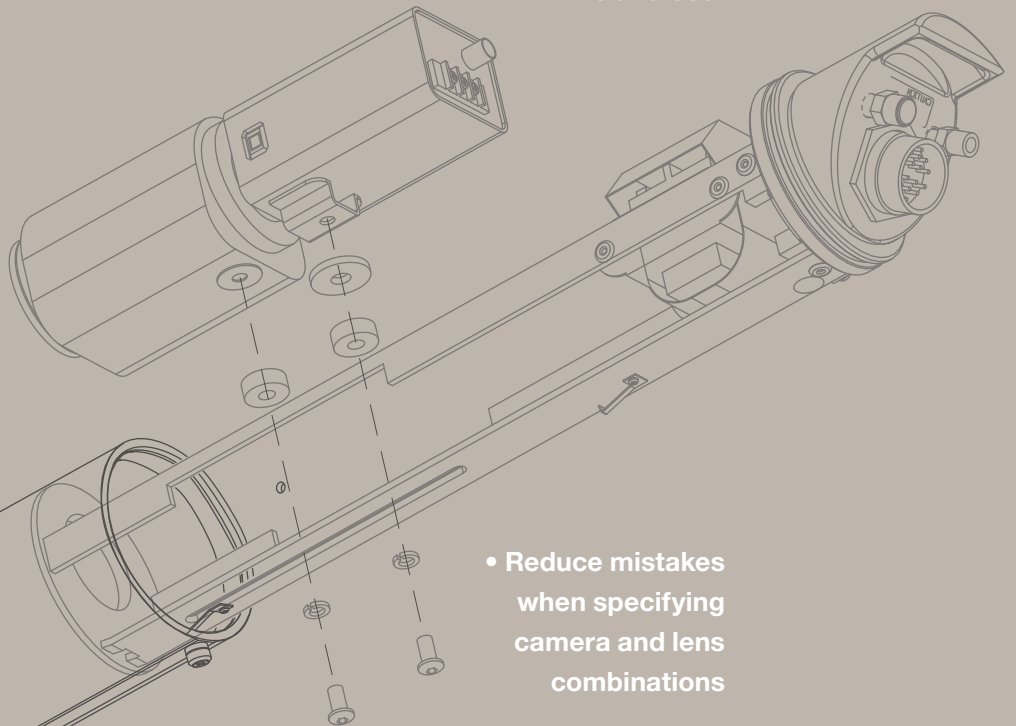



1950 Camino Vida Roble  
Suite 150  
Carlsbad, CA 92008  
800.421.1587

[www.linearcorp.com](http://www.linearcorp.com)

All these brands are now under one name.

