

INSTALLER: Place this manual in the plastic envelope provided and permanently attach to the wall near the pushbutton.

INSTALLATION AND OWNER'S MANUAL

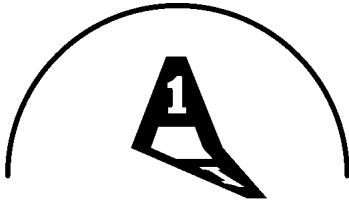

ACCESS ALLIANCE

PHOTOSYSTEM MODEL 112891

**FOR USE WITH COMMERCIAL VEHICULAR GARAGE DOOR OPENERS
USING THE ACCESS ALLIANCE SOLID STATE OPERATOR CONTROLS**

The purpose of this booklet is to provide assembly, installation and operation information concerning the Photosystem Photoelectric Accessory for COMMERCIAL vehicular garage door openers.

NOTICE

IT IS IMPORTANT THAT THIS INSTRUCTION MANUAL BE READ AND UNDERSTOOD COMPLETELY BEFORE INSTALLATION OR OPERATION IS ATTEMPTED.

NOTICE

THE IMPORTANT SAFEGUARDS AND INSTRUCTIONS IN THIS MANUAL CANNOT COVER ALL POSSIBLE CONDITIONS AND SITUATIONS WHICH MAY OCCUR DURING ITS USE. IT MUST BE UNDERSTOOD THAT COMMON SENSE AND CAUTION MUST BE EXERCISED BY THE PERSON(S) INSTALLING, MAINTAINING AND OPERATING THE EQUIPMENT DESCRIBED HEREIN. DO NOT USE THIS EQUIPMENT FOR ANY OTHER THAN ITS INTENDED PURPOSE: OPERATING OVERHEAD GARAGE DOORS.

Photosystem: An invisible infrared beam of light guards the door opening and reverses a downward moving door if the beam is broken by a stationary or moving object. The garage door opener motor control circuitry constantly monitors the Photosystem for proper operation.

Connections For Continuously Monitored Auxiliary Entrapment Protection Devices: The Photosystem (light beam across the door opening) can be easily connected to the Opener. Control circuitry monitors the device continuously for proper operation. Consult the factory for compatibility of other auxiliary entrapment protection devices.

Constant Contact To Close: The standard operation mode may require constant contact on the mechanical Push Button to close the door if the Photosystem device becomes misaligned or malfunctions. In this mode of operation, a Radio Transmitter cannot be used to close the door.

Momentary Contact To Close: After installing the Photosystem, Auxiliary Entrapment Protection Device, the close operation mode is automatically converted to momentary contact of the mechanical Push Button, and a portable Radio Transmitter can be used to close the door.

**READ THIS MANUAL CAREFULLY BEFORE
INSTALLATION OR USE.**



**DOOR OPENER WILL NOT OPERATE PROPERLY
UNTIL BEAM SENSOR IS INSTALLED AND
PROPERLY ADJUSTED! DO NOT OPERATE
DOOR OPENER UNTIL SENSOR IS FULLY
INSTALLED, ADJUSTED & TESTED.**

As of date of manufacture,
meets all ANSI/UL 325
Safety Requirements for
Vehicular Garage Door
Operators

Date Installed:
Your Dealer:



AN AUTOMATIC GARAGE DOOR SYSTEM POSES A THREAT OF INJURY OR EVEN DEATH. INSTALL THE PHOTOSYSTEM NO HIGHER THAN 4" - 6" ABOVE THE GARAGE FLOOR TO REDUCE THE RISK OF INJURY.



**RISK OF ENTRAPMENT.
DISCONNECT POWER TO THE OPENER BEFORE AND DURING INSTALLATION OF THIS ACCESSORY. DO NOT RECONNECT POWER TO OPENER UNTIL INSTRUCTED TO DO SO. ENSURE DOORWAY IS CLEAR BEFORE STARTING TESTING OF UNIT.**

INSTALLATION OF PHOTOSYSTEM

Identify which side of the garage door opening (if any) the sun is "likely" to shine into. As sunlight could cause undesirable operation, mount the sending unit (green LED below the window) on the side of the door opening exposed to the sun.

STEP 1: Mark the position of the Photosystem as follows: Mark a line on the left and right door jamb (close to the door track) **FOUR (4) inches AND SIX (6) inches** above the floor. *The top mark is the maximum height and the bottom line is the minimum height that the photosystem accessory can be placed.*

104382

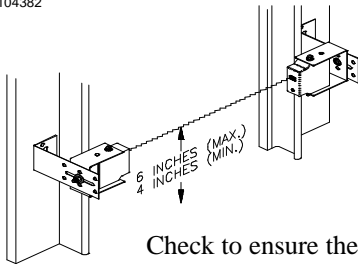

STEP 2: Mount the Photosystem "L" Brackets as follows:

Remove the four mounting brackets from the package

Your photosystem assembly is provided with a universal bracket set. Using either the transmitter or receiver (window up towards the ceiling), hold the "L" bracket and either the transmitter or receiver together while moving them in between the limit marks on the door jamb. Continue to move the photosystem assembly within the limit marks until it clears the door hardware. *See Illustration, left.*

Check to ensure the WINDOW ON THE FRONT OF THE PHOTOSYSTEM UNIT IS WITHIN THE LIMIT MARKS ON THE DOOR JAMB.

Place a mark in the center of the lag screw elongated mounting hole. Measure its position and place a similar mark on the opposite door jamb. The brackets may be temporarily mounted to the jamb with a 1" flat head nail (provided) using the small hole above the slot. Using two 5/16" X 1-1/2" lag screws (provided), permanently mount the "L" bracket to both door jambs.

STEP 3: Connect the Photosystem as follows:

Refer to last page for wiring diagrams of the Photosystem and garage door opener.

Run a wire pair around the garage door jamb between the transmitter and receiver "L" mounting brackets. **NOTE:** Leave about 12" of extra wire at each end. Use a minimum 22 gauge solid "trace" wire (one wire in set should be marked to identify it at each end) for interconnect.

Run a wire pair (20 or 22 gage solid wire) from the receiver position (unit with RED LED light in the front, may be either side of the door) back to the rear bulkhead of the garage door opener. **NOTE:** Leave about 12" of extra wire at the receiver end and about 24" of extra wire at the opener end. Use a minimum 22 gauge solid "trace" wire (one wire in set should be marked to identify it at each end) for interconnect.

Strip approximately 5/16" from each wire end at the photosystem units and at the opener.

Using two (2) wire nuts connect the wire ends at the Photosystem transmitter to the pigtail wire ends coming out of the transmitter unit. **The Photosystem is not polarized, however it is good practice to connect the trace wire ends (with black stripe) together and the unmarked wire ends together. See wiring diagram on the last page.**

Using two (2) wire nuts connect the wire ends at the Photosystem receiver to the pigtail wire ends coming out of the receiver unit. **The Photosystem is not polarized, however it is good practice to connect the trace wire ends (with black stripe) together and the unmarked wire ends together. See wiring diagram on last page.**

STEP 4 : Final Installation

Place the transmitter and receiver units into their respective brackets. Attach to brackets using the wing nuts.

Connect the interconnect wire pair to the garage door opener terminals. *Connect the trace wire (with black stripe) to the operator terminal marked “COM” and the solid color wire to the operator terminal marked “PHOTO”.* See Wiring Diagrams on the following page.

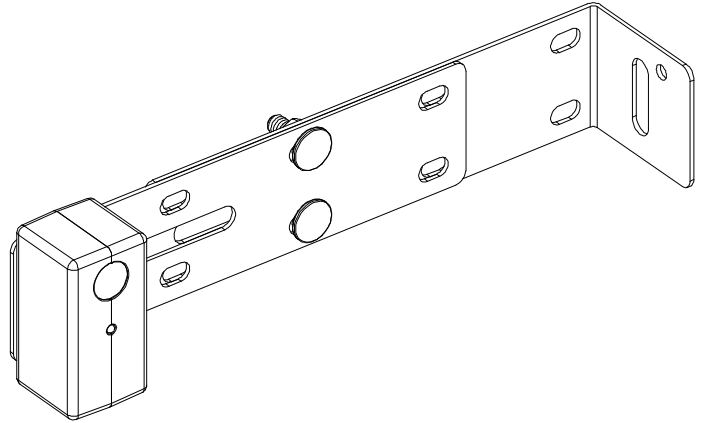

STEP 5 : Final Alignment and Test

Reconnect the power to the Garage Door Opener. Keep a portable transmitter with you to control the garage door opener. The red and green LED's will be on when the photosystem is properly aligned.

Place a solid object one foot in front of the transmitter or receiver. The green LED should go **OFF** and remain **OFF** until the object is removed. **NOTE:** *There may be a slight delay in returning to normal depending upon how long the photosystem was blocked.*

Move to the center of the door. Make sure the red and green LED lights are on. Move a solid object slowly through the beam. The green LED should go OFF and then ON. If not, check the wire connections (see Step 3).

At this time set or recheck the down limit adjustment and reversing system adjustment of the garage door opener following the procedure outlined in the operator installation and adjustment manual. It is **VERY IMPORTANT** that the door opener's inherent features operate as intended before completing the photosystem tests. Follow operator manufacture's instructions.

Place an opener insert box or a similar object (at least eight inches high) on the floor at the center of the door. Now, attempt to operate the door from the open limit position. **The door should NOT close** from the portable transmitter, but will close with constant pressure from the mechanical push button.

Remove the obstruction from the photosystem beam's path. Close the door. Toward the bottom of the doors downward movement, **CAREFULLY** move a solid object across the path of the beam at the center of the door. The door should **STOP**, pause for approximately one second and **OPEN**. Retest, breaking the beam one foot in front of both the transmitter and receiver unit while the door is moving downward. *The door must **STOP** and **OPEN** each time. If not, re-align the photosystem until proper operation is obtained.*

Tighten all mounting screws and bolts.

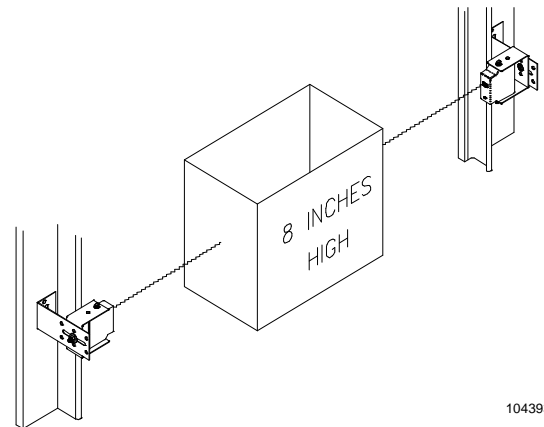

104393

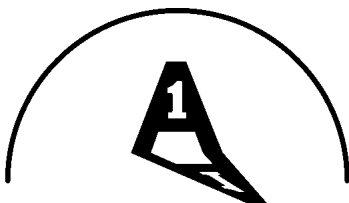

ACCESS ALLIANCE

WIRING DIAGRAMS - PHOTOSYSTEM

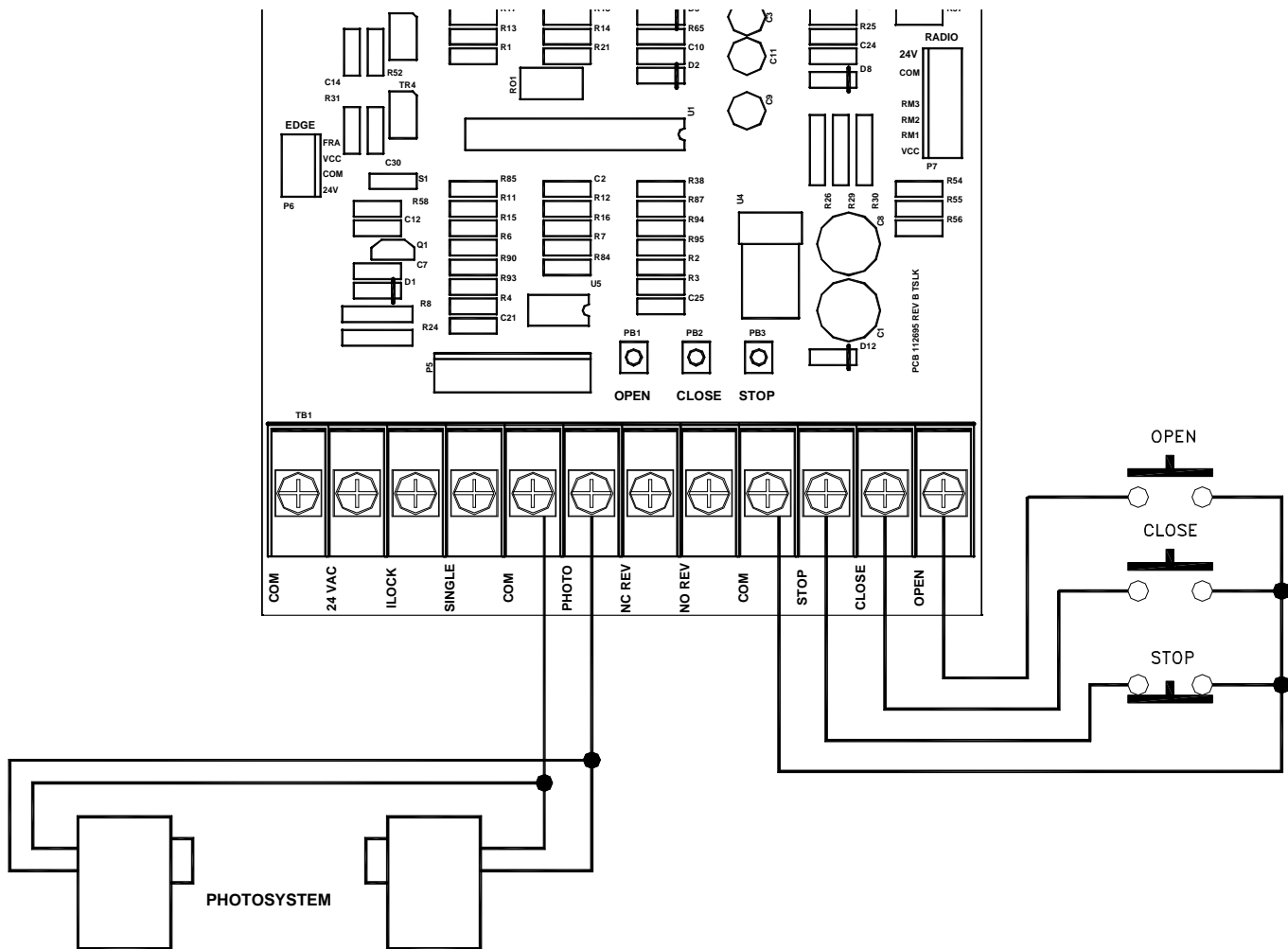

Note: Connect Photosystem to control terminals as show above. Connections to 3-button station is shown for reference only. Other terminal connections may be present or required for proper operation. Refer to manufacture's installation instructions for more information.

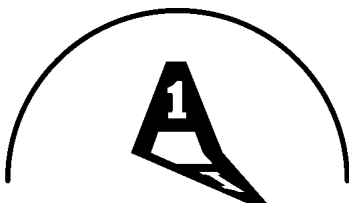

ACCESS ALLIANCE

Document 113257 REV A OCTOBER 2006